

USER'S MANUAL

CBF 110/130

CBF 110/130 T/TH/TP

CBF 110/130 LIGHT

CBF 110/130 LIGHT T/TH/TP

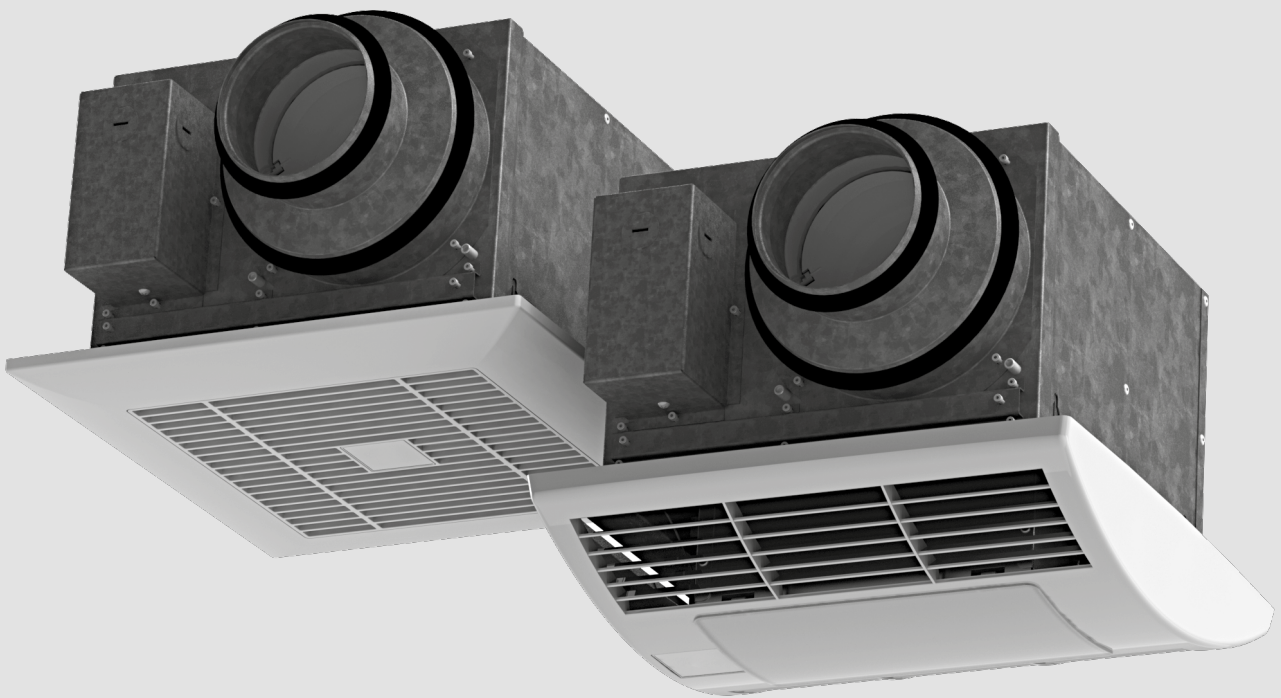

Centrifugal ceiling fan

CONTENTS

Safety requirements.....	2
Purpose.....	4
Delivery set.....	5
Designation key.....	5
Technical data.....	6
Design and operating principle	7
Mounting and set-up.....	9
Connection to power mains	12
Technical maintenance.....	14
Storage and transportation regulations.....	16
Manufacturer's warranty.....	17
Certificate of acceptance.....	19
Seller information.....	19
Installation certificate.....	19
Warranty card.....	19

This user's manual is a main operating document intended for technical, maintenance, and operating staff.

The manual contains information about purpose, technical details, operating principle, design, and installation of the CBF unit and all its modifications.

Technical and maintenance staff must have theoretical and practical training in the field of ventilation systems and should be able to work in accordance with workplace safety rules as well as construction norms and standards applicable in the territory of the country.



READ AND SAVE THESE INSTRUCTIONS

SAFETY REQUIREMENTS

All user's manual requirements as well as the provisions of all the applicable local and national construction, electrical, and technical norms and standards must be observed when installing and operating the unit.

Disconnect the unit from the power supply prior to any connection, servicing, maintenance, and repair operations.

Only qualified electricians with a work permit for electrical units up to 1000 V are allowed for installation. The present user's manual should be carefully read before beginning works.

Check the unit for any visible damage of the impeller, the casing, and the grille before starting installation. The casing internals must be free of any foreign objects that can damage the impeller blades.

While mounting the unit, avoid compression of the casing! Deformation of the casing may result in motor jam and excessive noise.

Misuse of the unit and any unauthorised modifications are not allowed.

Do not expose the unit to adverse atmospheric agents (rain, sun, etc.).

Transported air must not contain any dust or other solid impurities, sticky substances, or fibrous materials.

Do not use the unit in a hazardous or explosive environment containing spirits, gasoline, insecticides, etc.

Do not close or block the intake or extract vents in order to ensure the efficient air flow.

Do not sit on the unit and do not put objects on it.

The information in this user's manual was correct at the time of the document's preparation. The Company reserves the right to modify the technical characteristics, design, or configuration of its products at any time in order to incorporate the latest technological developments.

Never touch the unit with wet or damp hands.

Never touch the unit when barefoot.

This unit is not intended for use by persons (including children) with reduced physical, sensory or mental capabilities, or lack of experience and knowledge, unless they have been given supervision or instruction concerning use of the unit by a person responsible for their safety. Children should be supervised to ensure that they do not play with the unit.

Connection to the mains must be made through a disconnecting device, which is integrated into the fixed wiring system in accordance with the wiring rules for design of electrical units, and has a contact separation in all poles that allows for full disconnection under overvoltage category III conditions.

If the supply cord is damaged, it must be replaced by the manufacturer, its service agent, or similarly qualified persons in order to avoid a safety hazard.

Ensure that the unit is switched off from the supply mains before removing the guard.

Precautions must be taken to avoid the back-flow of gases into the room from the open flue of gas or other fuel-burning appliances.



**THE PRODUCT MUST BE DISPOSED SEPARATELY AT THE END OF ITS SERVICE LIFE.
DO NOT DISPOSE THE UNIT AS UNSORTED DOMESTIC WASTE.**

PURPOSE

The centrifugal ceiling extract fan CBF is designed for extract ventilation of small to medium-sized premises.
The unit is rated for continuous operation.



THE UNIT SHOULD NOT BE OPERATED BY CHILDREN OR PERSONS WITH REDUCED PHYSICAL, MENTAL, OR SENSORY CAPACITIES, OR THOSE WITHOUT THE APPROPRIATE TRAINING.

THE UNIT MUST BE INSTALLED AND CONNECTED ONLY BY PROPERLY QUALIFIED PERSONNEL AFTER THE APPROPRIATE BRIEFING.

THE CHOICE OF UNIT INSTALLATION LOCATION MUST PREVENT UNAUTHORISED ACCESS BY UNATTENDED CHILDREN.



**WARNING: NOT SUITABLE FOR USE WITH SOLID-STATE SPEEDCONTROLS
AVERTISSEMENT : NE CONVIENT PAS A DES REGULATEURS DE VITESSE A SEMI-CONDUCTEURS.**



THE UNIT MUST NOT BE OPERATED IN KITCHEN PREMISES.



CAUTION! FOR GENERAL VENTILATING USE ONLY. DO NOT USE TO EXHAUST HAZARDOUS OR EXPLOSIVE MATERIALS AND VAPORS

Transported air must not contain any flammable or explosive mixtures, evaporation of chemicals, sticky substances, fibrous materials, coarse dust, soot and oil particles or environments favourable for the formation of hazardous substances (toxic substances, dust, pathogenic germs).

DELIVERY SET

NAME	QUANTITY
Fan	1 pc.
LED lamp (for fans with the Light option)	2 pcs.
Cable gland	1 pc.
Mounting bracket	4 pcs.
Fastening kit	1 pc.
User's manual	1 pc.
Packing box	1 pc.

DESIGNATION KEY

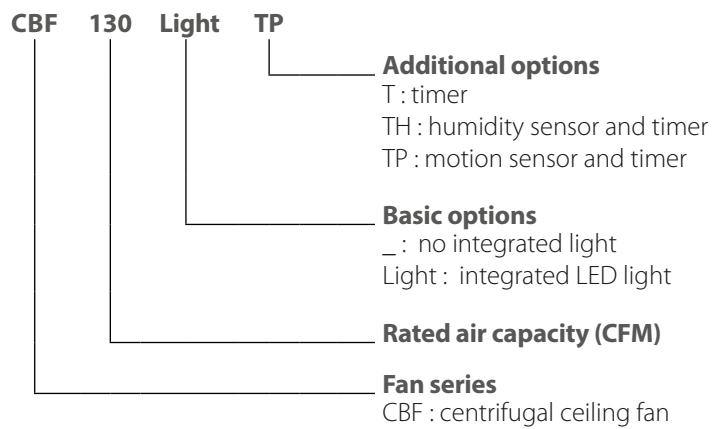

TECHNICAL DATA

The unit is designed for indoor application at ambient temperature from +34 °F up to +104 °F at max. RF 80 %.
Ingress protection rating against access to hazardous parts and water ingress is IP2X.

The unit design is constantly being improved, so some models may be slightly different from those ones described in this manual.

OVERALL AND CONNECTION DIMENSIONS OF THE FANS

CBF 110/130
CBF 110/130 T/TH/TP

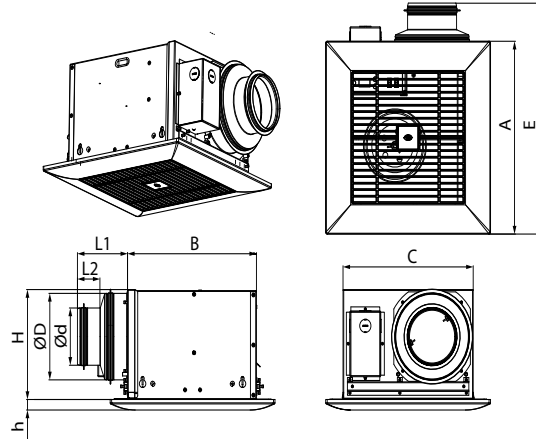

CBF 110/130 Light
CBF 110/130 Light T/TH/TP

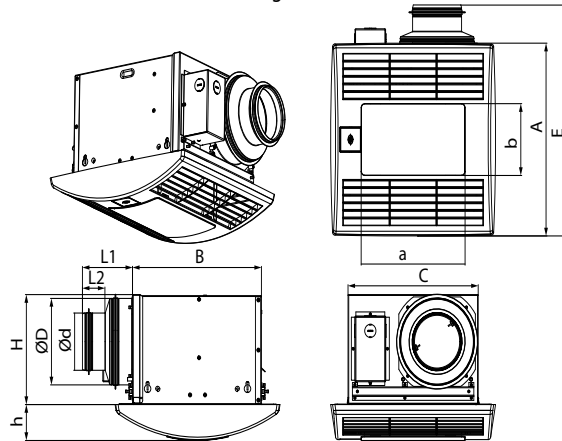

MODEL	DIMENSIONS, inch											
	D	D	L1	L2	A	B	C	E	H	H	A	B
CBF 110/130 CBF 110/130 T/TH/TP	5 7/8"	3 7/8"	3 15/16"	1 3/4"	13"	10 3/16"	10 1/4"	15 9/16"	7 3/8"	11/16"	-	-
CBF 110/130 Light CBF 110/130 Light T/TH/TP	5 7/8"	3 7/8"	3 15/16"	1 3/4"	13"	10 3/16"	10 1/4"	15 9/16"	7 3/8"	2 7/6"	8 3/16"	4 13/16"

TECHNICAL DATA

PARAMETER	CBF 110 CBF 110 T/TH/TP CBF 110 LIGHT CBF 110 LIGHT T/TH/TP		CBF 130 CBF 130 T/TH/TP CBF 130 LIGHT CBF 130 LIGHT T/TH/TP	
	Frequency [Hz]	60		
Speed	LS	HS	LS	HS
Voltage [V]	1 ~ 120			
Fan power [W]	16	27	23	35
Lamp power [W]*	2 x 10			
Max airflow, [CFM]	78	125	105	155
Max airflow, l/s	37	59	50	73
SFP, W/l/s	0,55	0,50	0,49	0,54
Weight	[kg]	5.3(6.4)		5.3(6.4)
	[lbs]	11.7(14.1)		11.7(14.1)
IP	2X			
SEC class	D		C	

* For fans with light only

DESIGN AND OPERATING PRINCIPLE

CBF 110/130 DC T/TH/TP

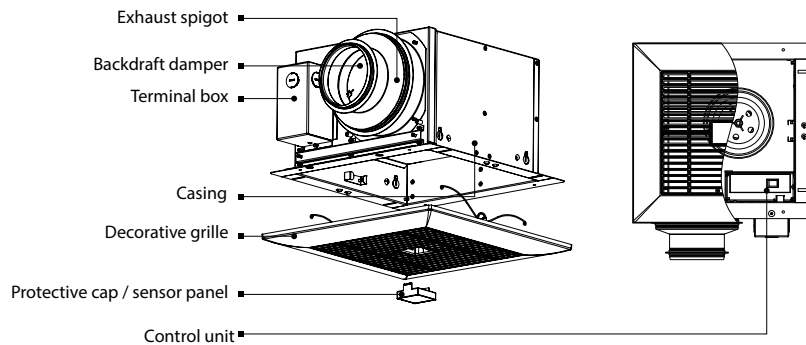

CBF 110/130 DC LIGHT T/TH/TP

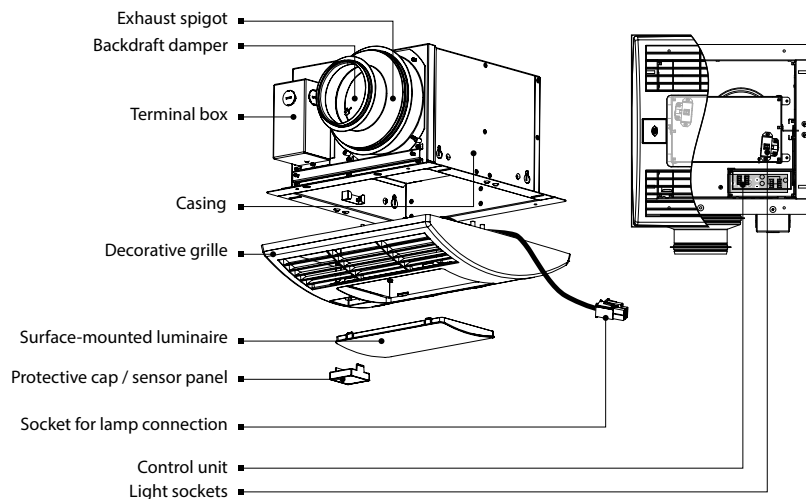

The fan casing is made of galvanized steel. The fan casing includes an exhaust spigot with a back draft damper to prevent back air flow. The terminal box comprises the terminals for wiring of the fan and is attached to the fan casing. The decorative grille is fixed to the casing via the springs inserted to the holders. The front panel is fixed via the grille slots. A single-phase electric motor with a centrifugal impeller with forward curved blades is fastened inside of the casing. Depending on the fan model the fan may be equipped with a LED lamp, a timer, a humidity or motion sensor.

Timer (t)

After an external switch, e.g. a light switch is turned off, the fan is turned on or goes to high speed after countdown of a set turn-on delay time, adjustable from 0 to 3 minutes.

After the fan is turned off it keeps running for a set turn-off delay time, adjustable from 1 to 90 minutes and the reverts to the initial operation status.

Motion sensor (tp)

In case of activation of the motion sensor the fan turns on or switches to the higher speed.

After no motion is detected more the fan keeps running for a set turn-off delay time, adjustable from 1 to 90 minutes, and the reverts to the initial operation status.

Humidity sensor (th)

If the indoor humidity exceeds the set humidity point adjustable from 50 % up to 90 %, the fan either turns on or goes to the higher speed.

After indoor humidity drops down the fan keeps running for a set turn-off delay time, adjustable from 1 to 90 minutes and the reverts to the initial operation status.

MOUNTING AND SET-UP



READ THE USER'S MANUAL BEFORE INSTALLING THE UNIT.



WARNING – TO REDUCE THE RISK OF FIRE, ELECTRIC SHOCK, OR INJURY TO PERSONS, OBSERVE THE FOLLOWING:

- Use this unit only in the manner intended by the manufacturer. If you have questions, contact the manufacturer.
- Before servicing or cleaning unit, switch power off at service panel and lock the service disconnecting means to prevent power from being switched on accidentally. When the service disconnecting means cannot be locked, securely fasten a prominent warning device, such as a tag, to the service panel.
- Installation work and electrical wiring must be done by qualified person(s) in accordance with all applicable codes and standards, including fire-rated construction.
- When cutting or drilling into wall or ceiling, do not damage electrical wiring and other hidden utilities.
- Ducted fans must always be vented to the outdoors. e) If this unit is to be installed over a tub or shower, it must be marked as appropriate for the application and be connected to a GFCI (Ground Fault Circuit Interrupter) – protected branch circuit"
- If this unit is to be installed over a tub or shower, it must be marked as appropriate for the application and be connected to a GFCI (Ground Fault Circuit Interrupter) – protected branch circuit

The fan is a component part and is not designed for stand-alone operation.

The fan is constructed for ceiling installation in the floor slab and fixation to the inter joist with the distance between the ceiling joists from 270 mm (10 ⁵/₈"") up to 680 mm (20 ³/₄"") using the removable fixing brackets or the fastening holes in the fan casing.

The installation place must be in compliance with local construction norms for units of this type.

Check the fan for mechanical damages prior to mounting .

Make sure that the casing comprises no foreign objects, such as paper or foil.

While mounting the fan sufficient service access for maintenance or repair operations must be provided.

The minimum gap between the fan and the ceiling is 5 mm (³/₁₆"").

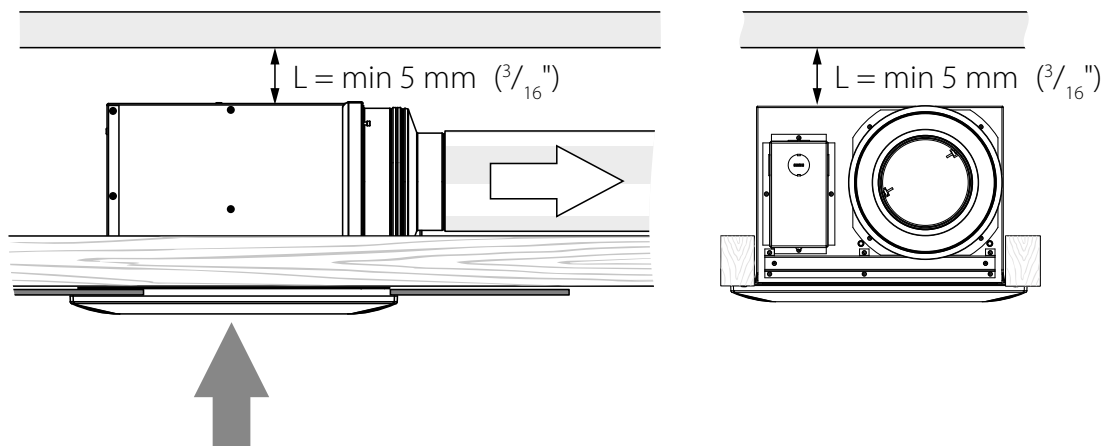

MOUNTING STEPS

1. Attach the fan to the interjoist using the screws.

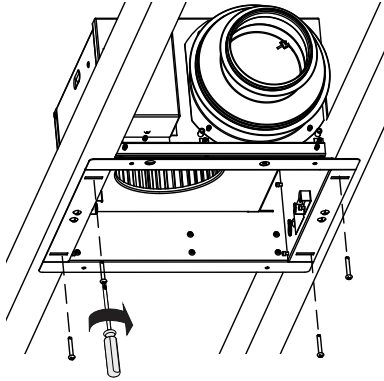

2. Connect the air duct of a required diameter.

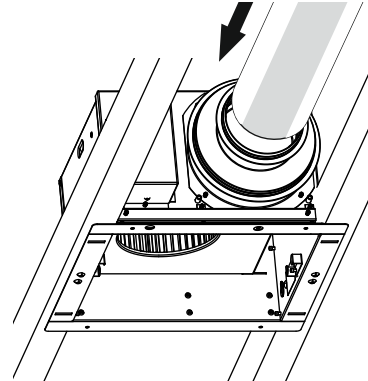

3. Connect the LED lamps (included in the delivery set) for the Light models.

Option: connect the humidity sensor or the motion sensor (specially ordered accessory).

For the Light models: connect the power socket of the LED lamp and the respective sockets in the terminal box.

For the TH models with a humidity sensor: remove the protective cap from the grille prior to its installation.

Route the contact socket of the sensor TH or TP via the opening in the grille and connect the sensor socket to the respective contact socket on the control unit.

Fix the sensor in the grille opening and cover the opening with a protective cap.

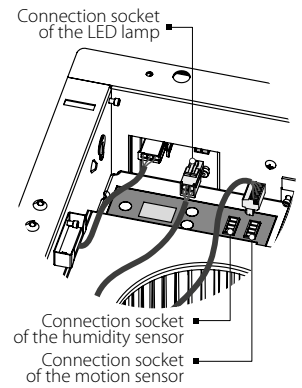
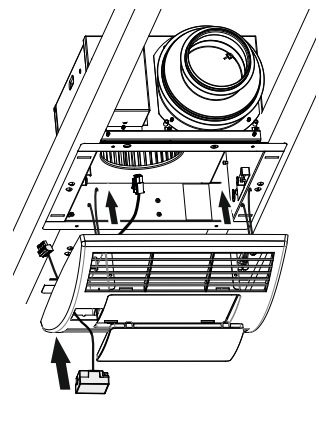
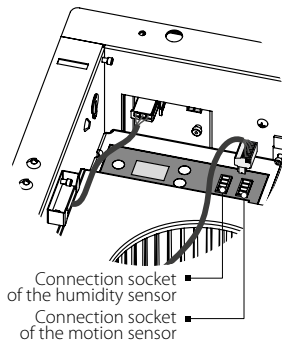
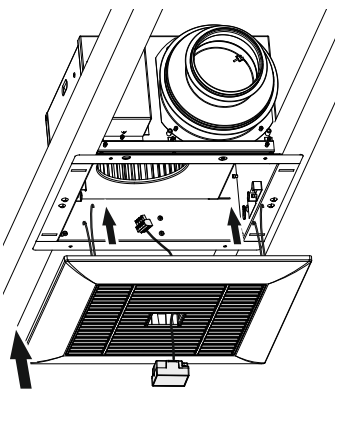

4. Install the decorative grille on the fan casing using the holders on the casing.

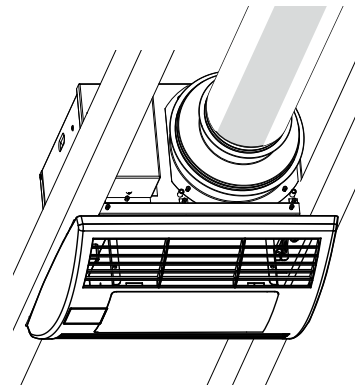
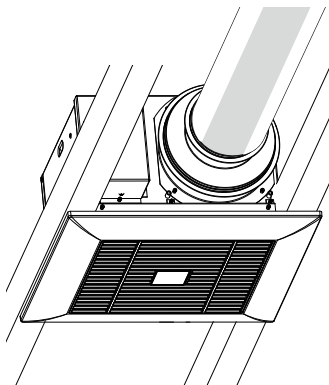

BASIC FAN INSTALLATION OPTIONS

Installation
between the ceiling joists

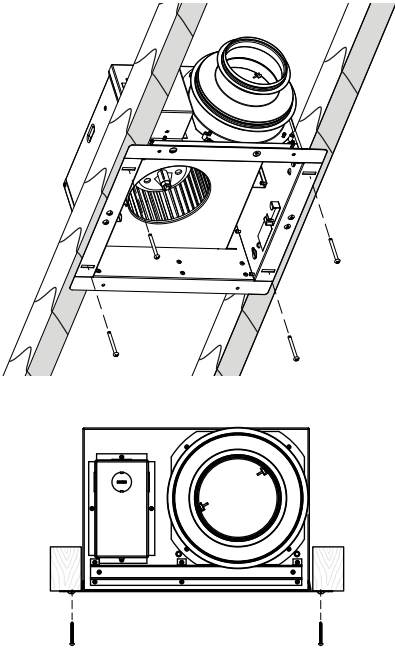

Side fixation
to one of the ceiling joists

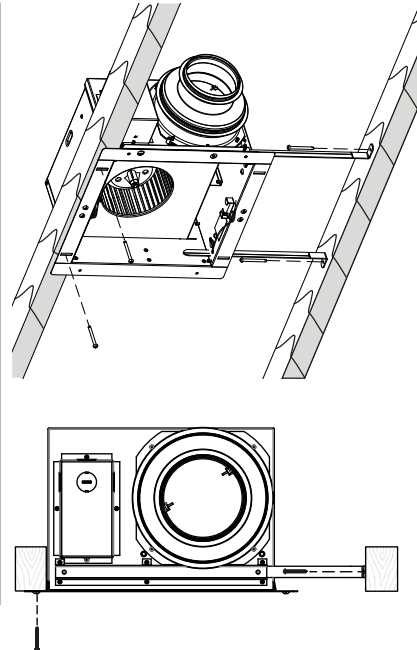

Fixation between
the ceiling joists using the mounting brackets

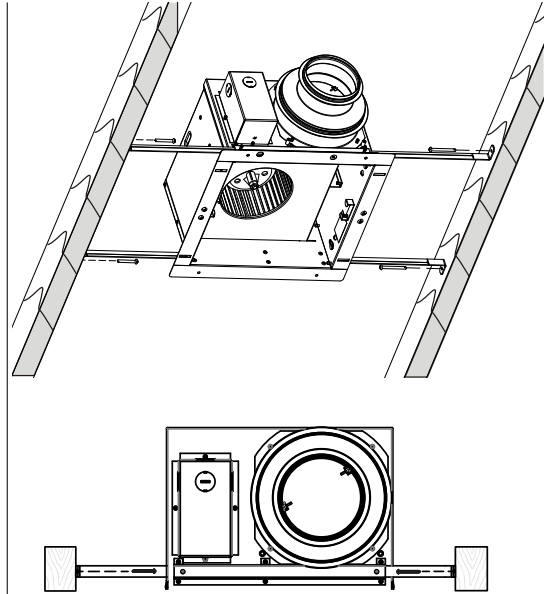

Additional fastening holes in the fan casing may be used for mounting purposes

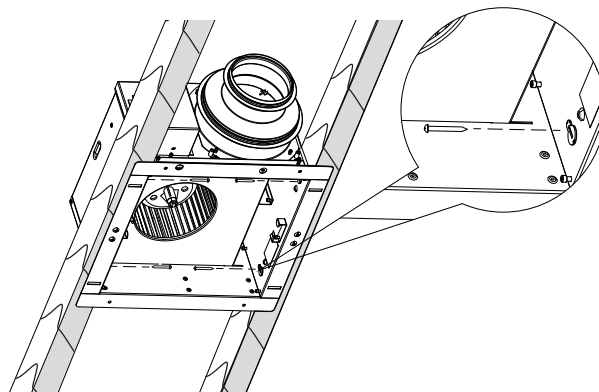

The ducting has a strong effect on the air flow, noise and energy use of the fan. Use the shortest, straightest duct routing possible for best performance, and avoid installing the fan with smaller ducts than recommended. Insulation around the ducts can reduce energy loss and inhibit mold growth. Fans installed with existing ducts may not achieve their rated airflow.

A 6 inch, round, rigid, metal duct is recommended for best performance.

Ensure duct joints and exterior penetrations are sealed with caulk or other similar material to create an air-tight path and to minimize building heat loss and gain and reduce the potential for condensation.

Place/wrap insulation around duct and/or fan to in order to minimize possible condensation buildup within the duct, as well as minimize building heat loss and gain.

CONNECTION TO POWER MAINS



**POWER OFF THE POWER SUPPLY PRIOR TO ANY OPERATIONS WITH THE UNIT.
THE UNIT MUST BE CONNECTED TO POWER SUPPLY BY A QUALIFIED ELECTRICIAN.
THE RATED ELECTRICAL PARAMETERS OF THE UNIT ARE GIVEN ON THE
MANUFACTURER'S LABEL.**



**ANY TAMPERING WITH THE INTERNAL CONNECTIONS IS PROHIBITED
AND WILL VOID THE WARRANTY.**

The fan is rated for connection to single-phase ac 120 V/ 60 Hz power supply.
The fan must be connected to power mains using durable, insulated and heat-resistant conductors (cables and wires) via the circuit breaker QF integrated into the house cabling system.
The external circuit breaker installation place must ensure unhampered access for emergency shutdown of the unit.

WIRING DIAGRAMS

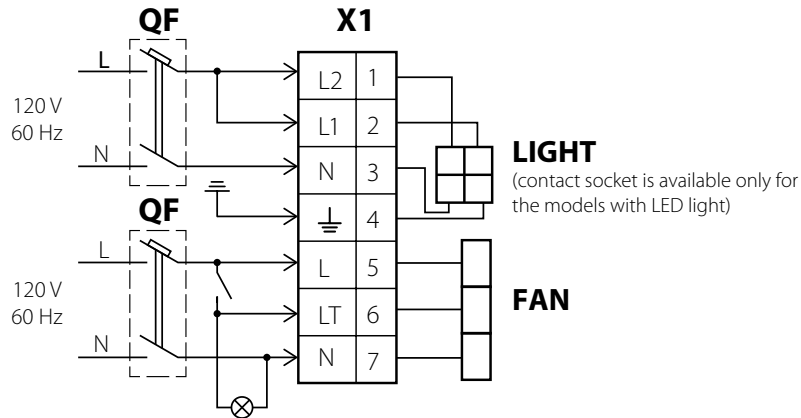

ACCESS TO THE TERMINAL BOX FOR WIRING THE FAN

Remove the decorative grille.
For accessing the connection terminals
loosen the screw on the terminal box
lid and take the lid off.

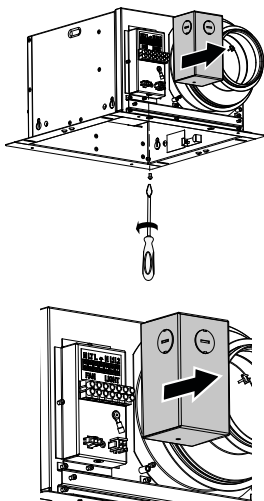

Remove the protective cap and install the cable gland.

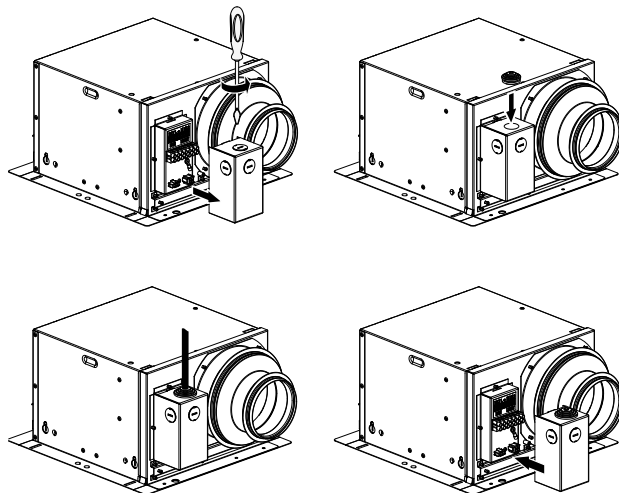

CONTROL UNIT WITH A SPEED SWITCH

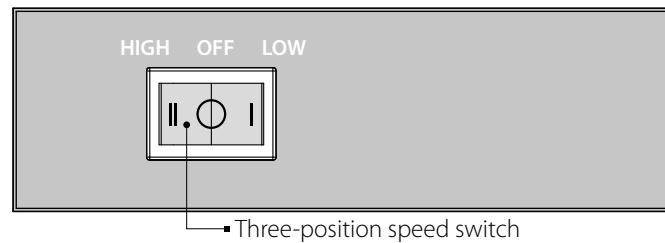

The fan with AC motor is controlled by a three-position switch. The switch has three positions:

OFF — the fan is turned off.

LOW — the fan operates at reduced performance (speed 1).

HIGH — the fan operates at maximum performance (speed 2).

When the power is turned on the fan will operate in one of the above modes.

MICROPROCESSOR CONTROL UNIT WITH INDICATION

The AC fan motor is operated by a microprocessor control unit. The front panel of the control unit comprises a light indicator, control buttons and two connectors for connection of the humidity and motion sensors.

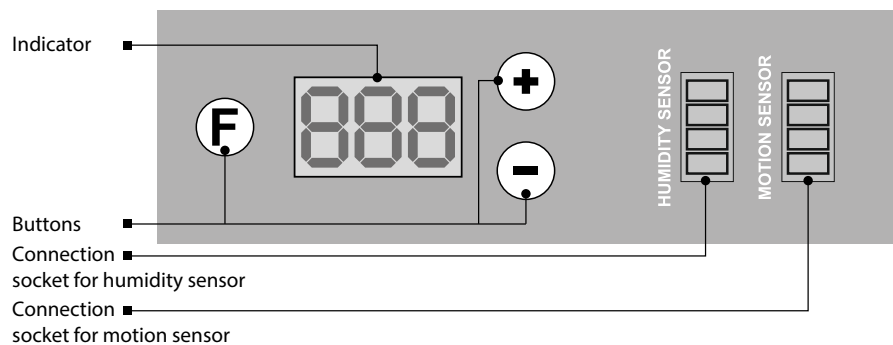

After the fan is connected to power supply, the indicator displays **---** for two seconds. After that the light indicator goes off and the fan starts operating in set mode. Once the button **F** is pressed the indicator displays the turn-off delay timer setting **-t-**, the first Setup menu entry. Use **+** or **-** buttons to navigate in the Setup menu. Press **F**, to select a current entry in the Setup menu. After that the indicator displays the selected parameter value (e.g., turn-off delay timer setting). Use **+** or **-** to change the value. Press **F** to come back to the Setup menu. If no button is pressed for 60 seconds, the indicator goes down.

Example

The indicator displays **-t-**. Once the button **-** is pressed, the Setup menu list goes one position down and the symbol **-d-** is displayed (refer to the Setup menu). Once the button **F** is pressed, the indicator displays the turn-on delay timer setting, which can be edited with the buttons **+** and **-**. Once the button **F** is pressed again, the Setup menu is displayed again and the edited value is saved.

To reset the menu to the factory settings press and hold the buttons **F** and **+** synchronously. In 5 seconds the indicator displays **dEF**, and goes off. The fan keeps running in a normal mode with the factory settings.

INDICATOR SYMBOLS OF THE MICROPROCESSOR CONTROL UNIT

-t- — turn-off delay timer adjustable from 1 to 90 minutes (default setting 15 minutes).

-d- — turn-on delay timer adjustable from 0 to 180 seconds with the increment of 10 seconds (default setting 0).

-h- — humidity set point adjustable from 50 % up to 90 % (default setting 75 %).

RFL — access to submenu of the fan operation mode.

Operation mode **SP.1** — the fan operates without any activation signal from the switch, humidity or motion sensor.

Operation mode **SP.2** — the fan operates with activation signal from the switch, humidity or motion sensor.

ESC — back to the upper setup menu level.

Once the switch is turned on or the humidity or motion sensor is activated, the fan switches from the mode **SP.1** to the mode **SP.2**. After a signal is no more received from the sensor in case of the indoor humidity normalization, or no more motion is detected in case of the fan shutdown, the fan keeps running for a set turn-off delay time and then switches from the mode **SP.2** to the mode **SP.1**.

SETUP OF THE OPERATION MODES **SP.1** AND **SP.2**

The **SP.1** and **SP.2** modes can take the following values for the fan with an AC motor:

OFF — the fan is turned off.

Lo — the fan operates at reduced performance.

H — the fan operates at maximum performance.

Example 1

SP.1 = OFF, SP.2 = Lo — with these activated settings the fan is constantly turned off. Once the switch is turned on or a sensor is activated, the fan starts to run at reduced performance.

Example 2

SP.1 = Lo, SP.2 = H — with these activated settings the fan runs at reduced performance. Once the switch is turned on or a sensor is activated, the fan starts to run with the maximum capacity. This setting is factory set and is the default setting.

TECHNICAL MAINTENANCE



DISCONNECT THE UNIT FROM POWER SUPPLY BEFORE ANY MAINTENANCE OPERATIONS!

MAKE SURE THE UNIT IS DISCONNECTED FROM POWER MAINS BEFORE REMOVING THE PROTECTION

The fan maintenance includes regular cleaning of the surfaces of dust and dirt. Replace the filter as required, but at least every 6 months. The impeller cleaning is shown below. Clean the impeller blades thoroughly every 6 months.

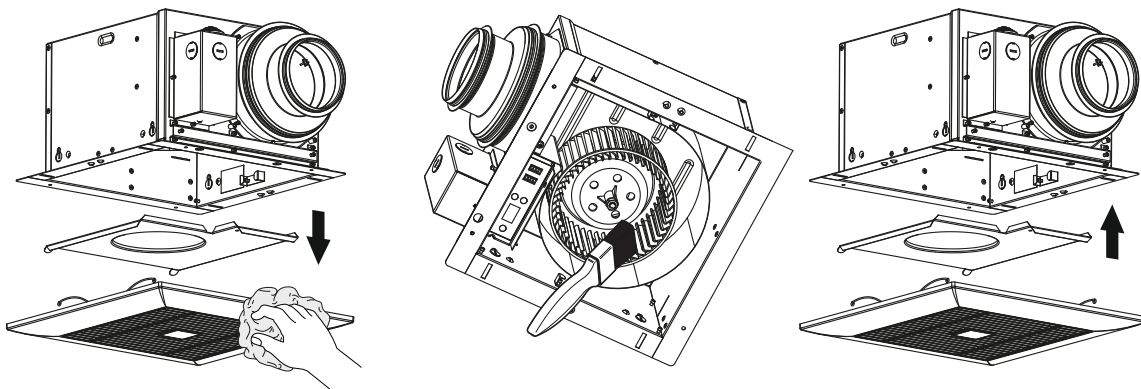

LAMP REPLACEMENT



DISCONNECT THE UNIT FROM POWER SUPPLY BEFORE ANY MAINTENANCE OPERATIONS!
MAKE SURE THE UNIT IS DISCONNECTED FROM POWER MAINS BEFORE REMOVING THE PROTECTION

1. Remove the decorative grille:

- Pull the grille to release the springs from the holders on the casing.
- Take out the lamp power socket from the respective socket on the casing.
- Take out the power socket of the sensors from the respective sockets on the control unit (applicable for TH and TP models).

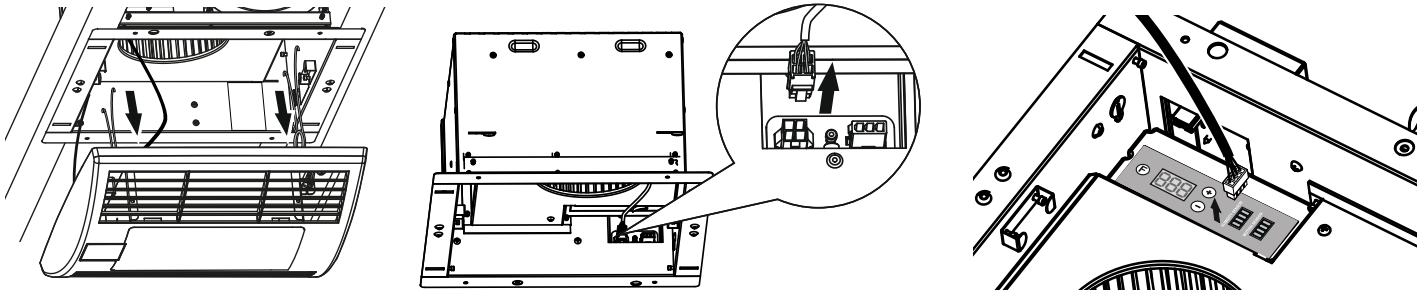

2. Take off the surface-mounted luminaire.

Press the holders on the reverse side of the grille frame and take off the surface-mounted luminaire.

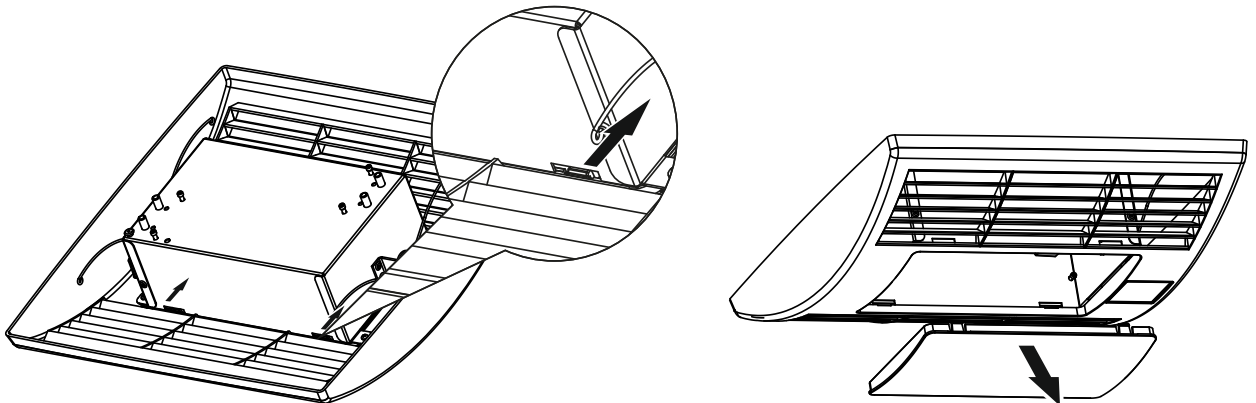

3. Replace the lamps.

4. Reassemble the unit in the reverse order.

TROUBLES AND TROUBLESHOOTING

TROUBLE	POSSIBLE REASONS	TROUBLESHOOTING
The fan does not get started.	No power supply.	Check the electric connections and the operation status of the circuit breaker.
	Motor jam.	Turn the fan off. Troubleshoot clogging of the impeller. Restart the fan.
Automatic circuit breaker tripping during the unit turning on.	Overcurrent as a result of short circuit in the electric circuit leads to tripping of the circuit breaker.	Disconnect the fan from power supply and contact the product Seller. Do not turn the fan on again!
Low air flow.	Air ducts or other components of the ventilation system are clogged. The impeller is clogged. The air ducts are damaged. The air dampers are closed.	Clean the air ducts, the impeller and other components of the ventilation system. Make sure that the air ducts are not damaged. Make sure that the air dampers and louvre shutters are open.

STORAGE AND TRANSPORTATION REGULATIONS

- Store the unit in the manufacturer's original packaging box in a dry closed ventilated premise with temperature range from +5 °C (+41 °F) to +40 °C (+104 °F) and relative humidity up to 70 %.
- Storage environment must not contain aggressive vapors and chemical mixtures provoking corrosion, insulation, and sealing deformation.
- Use suitable hoist machinery for handling and storage operations to prevent possible damage to the unit.
- Follow the handling requirements applicable for the particular type of cargo.
- The unit can be carried in the original packaging by any mode of transport provided proper protection against precipitation and mechanical damage. The unit must be transported only in the working position.
- Avoid sharp blows, scratches, or rough handling during loading and unloading.
- Prior to the initial power-up after transportation at low temperatures, allow the unit to warm up at operating temperature for at least 3-4 hours.

MANUFACTURER'S WARRANTY

Production meets standard operating requirements in the USA and Canada.

Vents US warrants to the original purchaser of the unit that it will be free from defects in materials or workmanship for a period of 24 months from the date of original purchase. The Vents US warrants to the original purchaser of the unit that the integrated control unit will be free from defects in materials and workmanship for a period of 24 months from the date of original purchase.

THERE ARE NO OTHER WARRANTIES, EXPRESS OR IMPLIED, INCLUDING, BUT NOT LIMITED TO, IMPLIED WARRANTIES OF MERCHANTABILITY OR FITNESS FOR A PARTICULAR PURPOSE.

During the stated warranty period, Vents US will, at its option, repair or replace, without charge, any product or part which is found to be defective under normal use and service. This warranty does not cover (a) normal maintenance and normal service or (b) any products or parts which have been subject to misuse, negligence, accident, improper maintenance or repair (other than by Vents US), faulty installation or installation contrary to recommended installation instructions. Labor to remove and replace products is not covered. The duration of any implied warranty is limited to the time period specified for the express warranty. Some states do not allow limitations on how long an implied warranty lasts, so the above limitation may not apply to you.

VENTS US OBLIGATION TO REPAIR OR REPLACE, AT VENTS US OPTION, SHALL BE THE PURCHASER'S SOLE AND EXCLUSIVE REMEDY UNDER THIS WARRANTY. VENTS US SHALL NOT BE LIABLE FOR INCIDENTAL, CONSEQUENTIAL OR SPECIAL DAMAGES ARISING OUT OF OR IN CONNECTION WITH PRODUCT USE OR PERFORMANCE.

Some states do not allow the exclusion or limitations of incidental or consequential damages, so the above limitation or exclusion may not apply to you. This warranty gives you specific legal rights, and you may also have other rights which vary from state to state. This warranty supersedes all prior warranties. If proof of sales date is absent, warranty period is calculated from the production date. The unit can be exchanged at the following address:

Vents-US
400 Murray Road, Cincinnati, OH 45217, USA
Tel: 1-888-640-0925, 513-583-5786, Fax: 513-268-4597
E-mail: support@ventsus.com
www.vents-us.com

Please follow guidelines in this manual for product problem-free operation.

CERTIFICATE OF ACCEPTANCE

Unit Type	Centrifugal ceiling extract fan
Model	
Serial Number	
Manufacture Date	
Quality Inspector's Stamp	

SELLER INFORMATION

Seller	
Address	
Phone Number	
E-mail	
Purchase Date	
This is to certify acceptance of the complete unit delivery with the user's manual. The warranty terms are acknowledged and accepted.	
Customer's Signature	

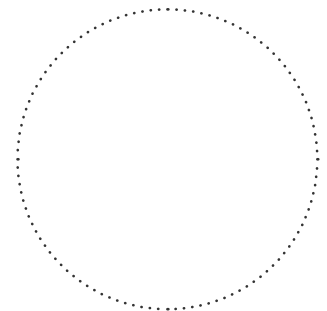

Seller's Stamp

INSTALLATION CERTIFICATE

The unit _____ is installed pursuant to the requirements stated in the present user's manual.	
Company name	
Address	
Phone Number	
Installation Technician's Full Name	
Installation Date:	Signature:
The unit has been installed in accordance with the provisions of all the applicable local and national construction, electrical and technical codes and standards. The unit operates normally as intended by the manufacturer.	
Signature:	

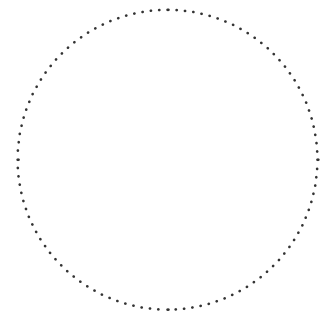

Installation Stamp

WARRANTY CARD

Unit Type	Centrifugal ceiling extract fan
Model	
Serial Number	
Manufacture Date	
Purchase Date	
Warranty Period	
Seller	

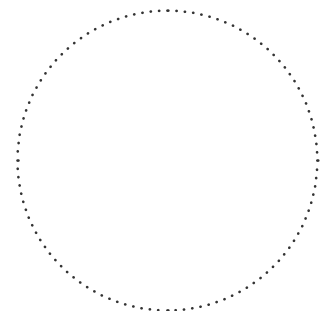

Seller's Stamp

