

USER'S MANUAL

Airvents CFH



Air handling unit

CONTENTS

Safety requirements.....	2
Purpose	5
Delivery set	6
Designation key	7
Technical data	8
Unit design and operation logic.....	10
Installation and set-up	11
Connection to power mains	14
Technical maintenance	16
Control measurements of operating parameters	19
Alarms	20
Troubleshooting.....	21
Storage and transportation regulations.....	22
Manufacturer's warranty.....	22
Certificate of acceptance.....	23
Seller information	23
Installation certificate.....	23
Warranty card.....	23

This user's manual is a main operating document intended for technical, maintenance, and operating staff.

The manual contains information about purpose, technical details, operating principle, design, and installation of the Airvents CFH unit and all its modifications.

Technical and maintenance staff must have theoretical and practical training in the field of ventilation systems and should be able to work in accordance with workplace safety rules as well as construction norms and standards applicable in the territory of the country.

SAFETY REQUIREMENTS

THE UNIT MUST BE GROUNDED!

DO NOT BEND THE POWER CABLE.

AVOID DAMAGING THE POWER CABLE.

DO NOT PUT ANY FOREIGN OBJECTS ON THE POWER CABLE.

DO NOT USE DAMAGED EQUIPMENT OR CABLES WHEN CONNECTING THE UNIT TO POWER MAINS.

DO NOT TOUCH THE UNIT CONTROLS WITH WET HANDS.

DO NOT CARRY OUT THE INSTALLATION AND MAINTENANCE OPERATIONS WITH WET HANDS.

DO NOT ALLOW CHILDREN TO OPERATE THE UNIT.

DO NOT STORE ANY EXPLOSIVE OR HIGHLY FLAMMABLE SUBSTANCES IN CLOSE PROXIMITY TO THE UNIT.

DO NOT OPEN THE UNIT DURING OPERATION.

DO NOT BLOCK THE AIR DUCT WHEN THE UNIT IS SWITCHED ON.

DO NOT SIT ON THE UNIT AND AVOID PLACING FOREIGN OBJECTS ON IT.

UNPACK THE UNIT WITH CARE.

WHILE INSTALLING THE UNIT, FOLLOW THE SAFETY REGULATIONS SPECIFIC TO THE USE OF ELECTRIC TOOLS.

DO NOT LAY THE POWER CABLE OF THE UNIT IN CLOSE PROXIMITY TO HEATING EQUIPMENT.

DO NOT OPERATE THE UNIT OUTSIDE THE TEMPERATURE RANGE STATED IN THE USER'S MANUAL.

DO NOT OPERATE THE UNIT IN AGGRESSIVE OR EXPLOSIVE ENVIRONMENTS.

DO NOT WASH THE UNIT WITH WATER.

PROTECT THE ELECTRIC PARTS OF THE UNIT AGAINST INGRESS OF WATER.

DISCONNECT THE UNIT FROM POWER MAINS PRIOR TO ANY TECHNICAL MAINTENANCE.

WHEN THE UNIT GENERATES UNUSUAL SOUNDS, ODOR, OR EMITS SMOKE, DISCONNECT IT FROM POWER SUPPLY AND CONTACT THE SELLER.

DO NOT DIRECT THE AIR FLOW PRODUCED BY THE UNIT TOWARDS OPEN FLAME OR IGNITION SOURCES.

IN CASE OF CONTINUOUS OPERATION OF THE UNIT, PERIODICALLY CHECK THE SECURITY OF MOUNTING.

USE THIS UNIT ONLY IN THE MANNER INTENDED BY THE MANUFACTURER. IF YOU HAVE QUESTIONS, CONTACT THE MANUFACTURER.

THE UNIT SHOULD NOT BE OPERATED BY CHILDREN OR PERSONS WITH REDUCED PHYSICAL, MENTAL, OR SENSORY CAPACITIES, OR THOSE WITHOUT THE APPROPRIATE TRAINING.

THE CHOICE OF UNIT INSTALLATION LOCATION MUST PREVENT UNAUTHORIZED ACCESS BY UNATTENDED CHILDREN.

READ THE USER'S MANUAL BEFORE INSTALLING THE UNIT.

INSTALLATION WORK AND ELECTRICAL WIRING MUST BE DONE BY QUALIFIED PERSON(S).

WHEN CUTTING OR DRILLING INTO WALL OR CEILING, DO NOT DAMAGE ELECTRICAL WIRING AND OTHER HIDDEN UTILITIES.

DO NOT MOUNT ROOM-TO-ROOM FAN IN A FIRE-RATED WALL.

**POWER OFF THE POWER SUPPLY PRIOR TO ANY OPERATIONS WITH THE UNIT.
THE UNIT MUST BE CONNECTED TO POWER SUPPLY BY A QUALIFIED
ELECTRICIAN.**

**THE RATED ELECTRICAL PARAMETERS OF THE UNIT ARE GIVEN ON THE
MANUFACTURER'S LABEL.**

**ANY TAMPERING WITH THE INTERNAL CONNECTIONS IS PROHIBITED
AND WILL VOID THE WARRANTY.**

**INSTALLATION ONLY BY EXPERTS AND ONLY IN ACCORDANCE WITH
LOCAL REQUIREMENTS AND NATIONAL ELECTRICAL CODE**

**DISCONNECT THE UNIT FROM POWER SUPPLY BEFORE ANY MAINTENANCE
OPERATIONS!**

**ENSURE THAT THE UNIT IS SWITCHED OFF FROM THE SUPPLY MAINS BEFORE
REMOVING THE GUARD.**

**FOLLOWING THE REGULATIONS STIPULATED HEREIN WILL ENSURE A LONG
AND TROUBLE-FREE OPERATION OF THE UNIT.**

**USER'S WARRANTY CLAIMS SHALL BE SUBJECT TO REVIEW ONLY UPON
PRESENTATION OF THE UNIT, THE PAYMENT DOCUMENT AND THE USER'S
MANUAL WITH THE PURCHASE DATE STAMP.**

**TO REDUCE THE RISK OF FIRE, ELECTRIC SHOCK, OR INJURY TO PERSONS,
OBSERVE THE FOLLOWING:**

**USE THIS UNIT ONLY IN THE MANNER INTENDED BY THE MANUFACTURER. IF
YOU HAVE QUESTIONS, CONTACT THE MANUFACTURER.**

**BEFORE SERVICING OR CLEANING UNIT, SWITCH POWER OFF AT SERVICE
PANEL AND LOCK THE SERVICE DISCONNECT MEANS TO PREVENT
POWER FROM BEING SWITCHED ON ACCIDENTALLY. WHEN THE SERVICE
DISCONNECTING MEANS CANNOT BE LOCKED, SECURELY FASTEN A
PROMINENT WARNING DEVICE, SUCH AS A TAG, TO THE SERVICE PANEL**

**FOR GENERAL VENTILATING USE ONLY. DO NOT USE TO EXHAUST
HAZARDOUS OR EXPLOSIVE MATERIALS AND VAPORS.**



**THE PRODUCT MUST BE DISPOSED SEPARATELY AT
THE END OF ITS SERVICE LIFE.
DO NOT DISPOSE THE UNIT AS UNSORTED
DOMESTIC WASTE**

PURPOSE



CAUTION!

FOR GENERAL VENTILATING USE ONLY.

DO NOT USE TO EXHAUST HAZARDOUS OR EXPLOSIVE MATERIALS AND VAPORS AS WELL AS FLAMMABLE MIXTURES, EVAPORATION OF CHEMICALS, STICKY SUBSTANCES, FIBROUS MATERIALS, COARSE DUST, SOOT AND OIL PARTICLES OR ENVIRONMENTS FAVOURABLE FOR THE FORMATION OF HAZARDOUS SUBSTANCES (TOXIC SUBSTANCES, DUST, PATHOGENIC GERMS).

FOR USE IN NON FIRE RATED INSTALLATIONS ONLY.

FOR USE IN ONE- AND TWO-FAMILY DWELLINGS ONLY.

The air handling unit with heat recovery is designed for integration into central mechanical ventilation systems.

The unit is rated for continuous operation.

Transported air must not contain any flammable or explosive mixtures, evaporation of chemicals, sticky substances, fibrous materials, coarse dust, soot and oil particles or environments favourable for the formation of hazardous substances (toxic substances, dust, pathogenic germs).

DELIVERY SET

Name	Number
Unit	1 pc.
User's manual	1 pc.
Technical data sheet	1 pc.
Automation wiring	1 pc.
Control panel - according to the kit ordered	1 pc.
User's manual for automation	1 pc.
Packing box	1 pc.

DESIGNATION KEY

TM	Casing size	Core type	Installation	Nominal airflow	Heater type	Heat exchanger type	Cooling coil type	Service side	Controller
Airvents	AV01 AV02 AV03 AV07 AV12	CF - counterflow R - rotary	P - ceiling H - double-deck V - vertical	1000 1200 1500 2500 3500 5000 6000 9000	HE - electric HW - water _ - no heater	E - enthalpy heat exchanger _ - sensible heat exchanger	CDX - DX-coil CW - water coil _ - no cooling	L - left R - right	A30 - Kvent with thTune A31 - Kvent A32 - Kvent with pGDE A21 - wireless control system A25 - control panel with touch screen

TECHNICAL DATA

The unit is designed for indoor or sheltered use. The installation conditions must prevent ingress of atmospheric precipitations and direct solar radiation at the ambient temperatures from -31 °F up to +122 °F. Outdoor unsheltered mounting is allowed provided an extra cover and weather hoods are installed on the air ducts (not included in the delivery set).

The frost protection for the water drainage and connected pipelines must be provided during sub-zero ambient temperatures (if the unit is equipped with an air cooler). The heat medium temperature in the water heat exchangers (if available) must be sufficient to prevent its freezing. Hazardous parts access and water ingress protection rating:

- IP54 for the unit motors
- IP42 for the assembled unit connected to the air ducts without extra cover or weather hoods
- IP44 for the assembled unit with connected air ducts, extra cover and weather hoods (specially ordered accessories)
- IP00 for the unit not connected to the air ducts

The unit design is constantly being improved, thus some models may be slightly different from those described in this manual.

UNIT OVERALL DIMENSIONS, inch

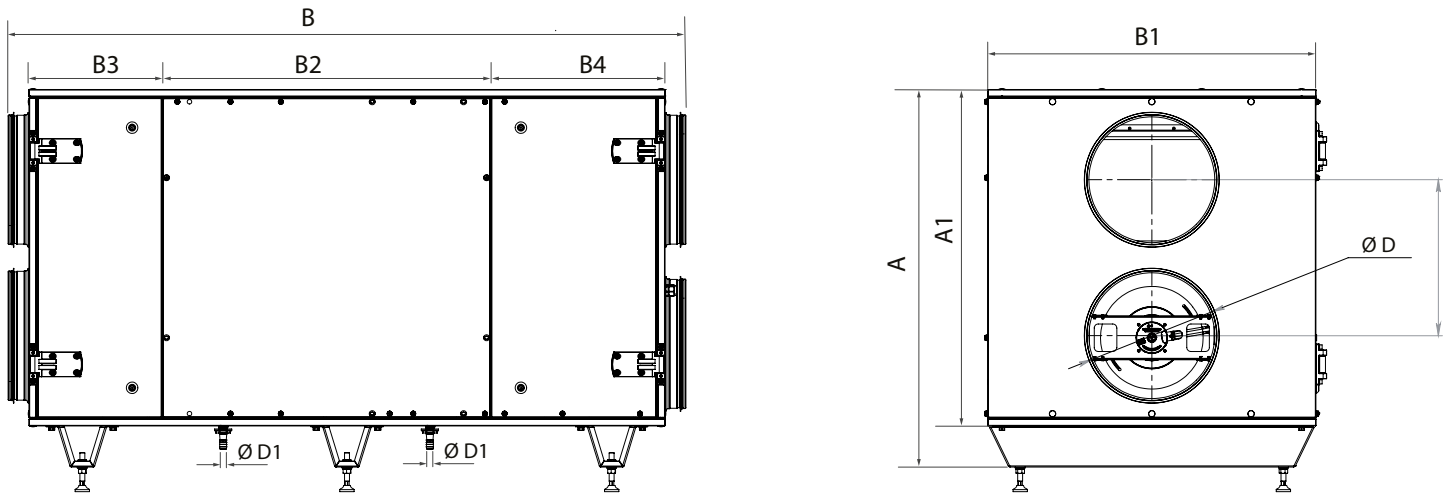

Model	A	A1	B	B1	B2	B3	B4	D	D1
AV01 CFH 800(1200)	36.2	32.3	65.0	31.5	31.5	11.9	15.8	12.4	0.8

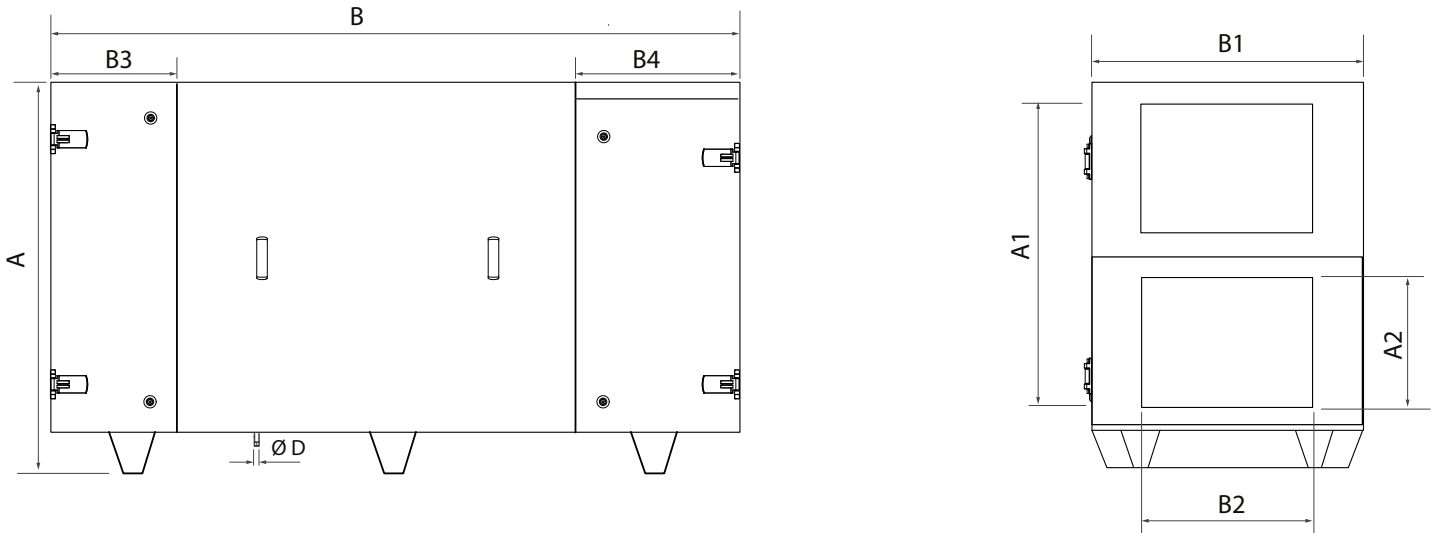

Model	A	A1	A2	B	B1	B2	B3	B4	D
AV02 CFH 1500-R(L) AV02 CFH 2500-R(L)	41.7	33.0	13.8	74.0	31.1	23.6	12.8	16.7	0.71
AV03 CFH 3500-R(L)	54.7	39.5	15.7	86.6	35.0	27.6	14.1	17.3	
AV07 CFH 5000-R(L) AV07 CFH 6000-R(L)	59.8	48.0	19.7	90.6	56.3	39.4	18.9	27.2	

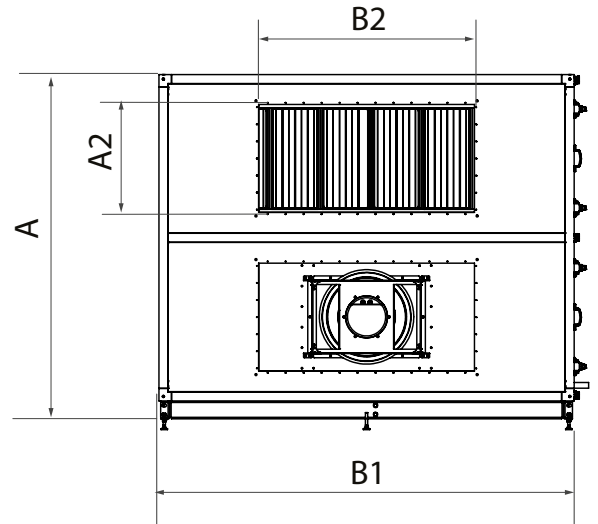
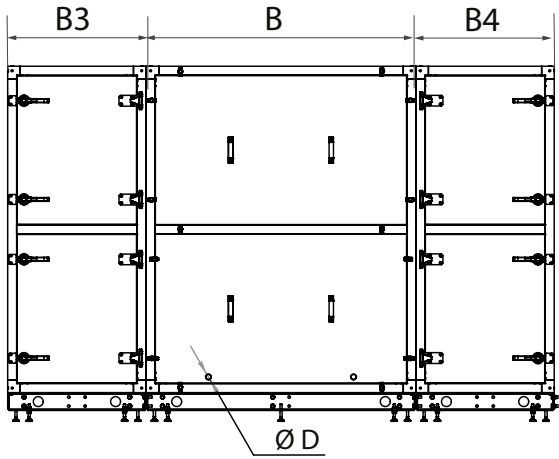

Model	A	A2	B	B1	B2	B3	B4	D
AV12 CFH 9000	75.4	23.6	59.0	90.9	47.2	30.3	30.3	1.3

The full technical data list is stated in the supplied technical data sheet.

UNIT DESIGN AND OPERATION LOGIC

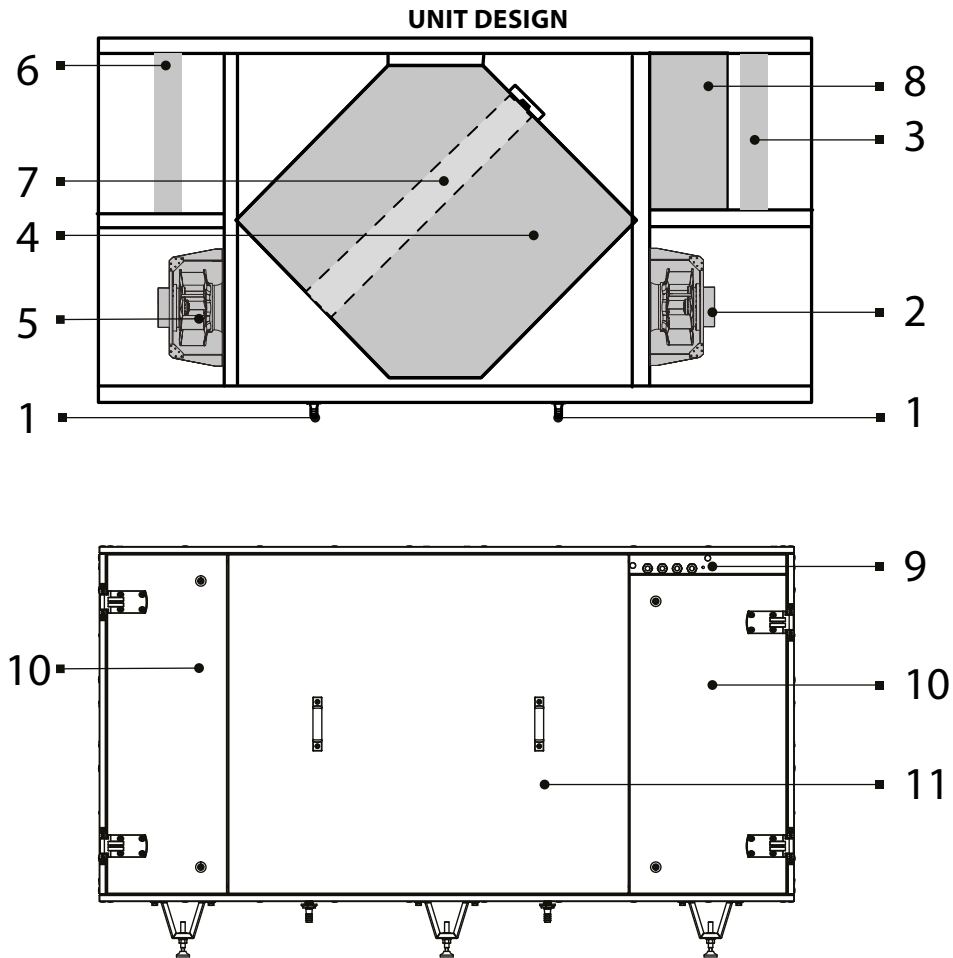

- 1: drain pipe
- 2: supply fan
- 3: extract filter
- 4: heat exchanger
- 5: extract fan
- 6: supply filter
- 7: bypass damper
- 8: control unit
- 9: sealed leads
- 10: service doors
- 11: service panel

* Units can be equipped with air dampers (purchased separately.)

The air damper is designed for automatic shutoff of the air duct during the system shutoff. The air dampers of the air handling units are Class 3 for air tightness according to the EN 1751 standard. The dampers contain counter-rotating aluminium shutters with high aerodynamic performance. The shutters may be equipped with extra cold proof heat insulation for extreme temperature conditions. Smooth air flow control is ensured by means of the gear drive made of robust heat-resistant plastic. The damper operation is controlled by means of the spring-return electric drive for guaranteed locking of the damper shutters in the closed position in case of an emergency power outage.

INSTALLATION AND SET-UP



IF A UNIT HAVING PROVISION FOR CONNECTION OF A FRESH AIR DISCHARGE DUCT DOES NOT ALSO HAVE PROVISION FOR CONNECTION OF AN INDOOR AIR INTAKE DUCT, APPLICABLE INSTALLATION CODES MAY LIMIT THE UNIT TO INSTALLATION ONLY IN A SINGLE-STORY RESIDENCE.

The units are available in left- and right-sided modifications with the right or left service side. All the assembly units are accessible on the service side.

Left-sided modification (service side view)

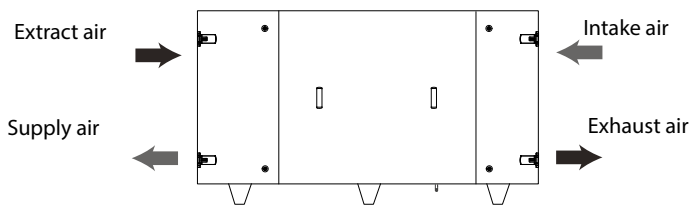

Right-sided modification (service side view)

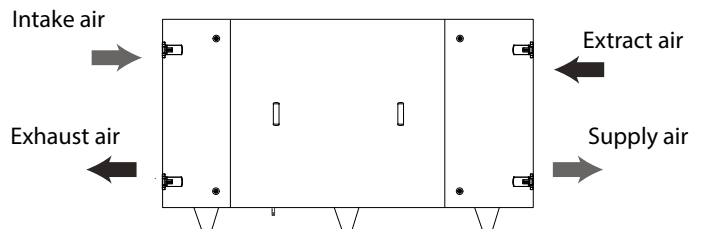

Connection of the air ducts is shown with the stickers of the respective colours: yellow for the extract air duct, green for the intake air duct, red for the supply air duct and brown for the exhaust air duct.

CFH 9000 units are supplied in sections.

Before installation of the unit it is necessary to connect the sections and fix them with screws.

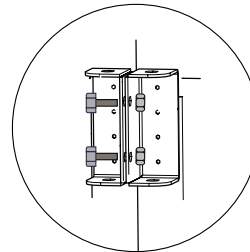
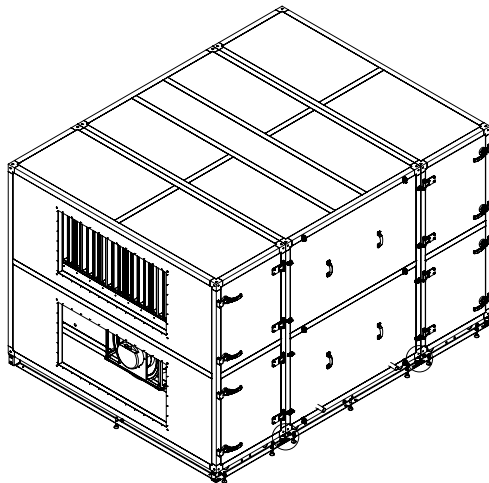

During installation works sufficient maintenance and service access must be provided. The recommended minimum distances from the unit to the walls are shown below.

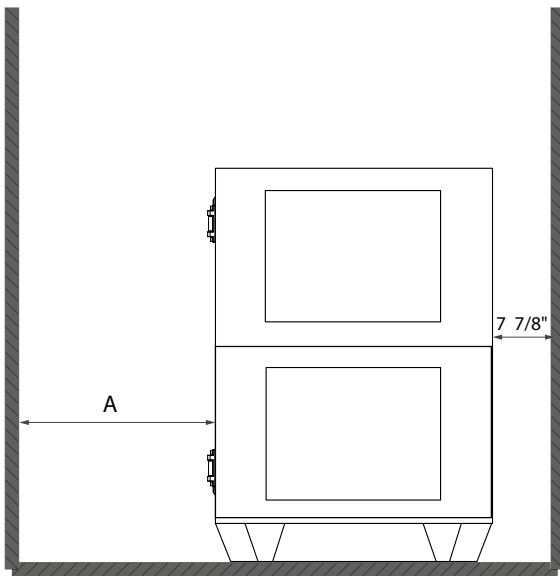

Casing dimensions	A
AV01 CFH AV02 CFH AV03 CFH	23 5/8"
AV07 CFH AV12 CFH	31 1/2"

The delivery set includes removable levelling feet to adjust horizontal levelling of the unit and provide required clearance from the floor to enable correct mounting of the condensed water drainage.

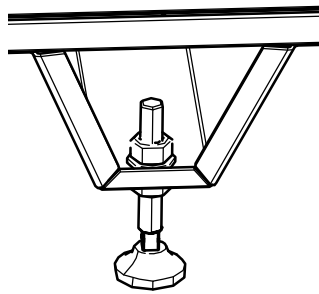

Condensate drainage

The unit is equipped with drain pipes to remove condensed water outside of the unit. U-traps must be connected to the drain pipes. Dimensions of the U-trap must be selected based on air pressure of the fan and are stated in the table.

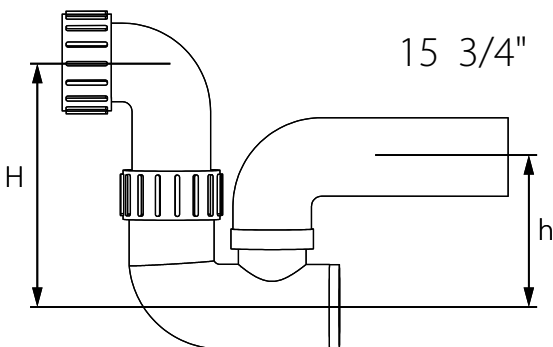

Total Fan Pressure		Size H		Size h	
[Pa]	[inWG]	[mm]	[in]	[mm]	[in]
<600	< 2.4	100	3 15/16	50	1 15/16
600-1000	2.4-4	140	5 1/2	70	2 3/4
1000-1400	4-5.6	190	7 1/2	95	3 3/4
1400-1800	5.6-7.2	240	9 7/16	120	4 3/4
1800-2200	7.2-8.8	290	11 7/16	145	5 11/16
2200-2600	8.8-10	340	13 3/8	170	6 11/16

Connect the drain pipe, U-trap and sewage system using metal, plastic or rubber connecting pipes.

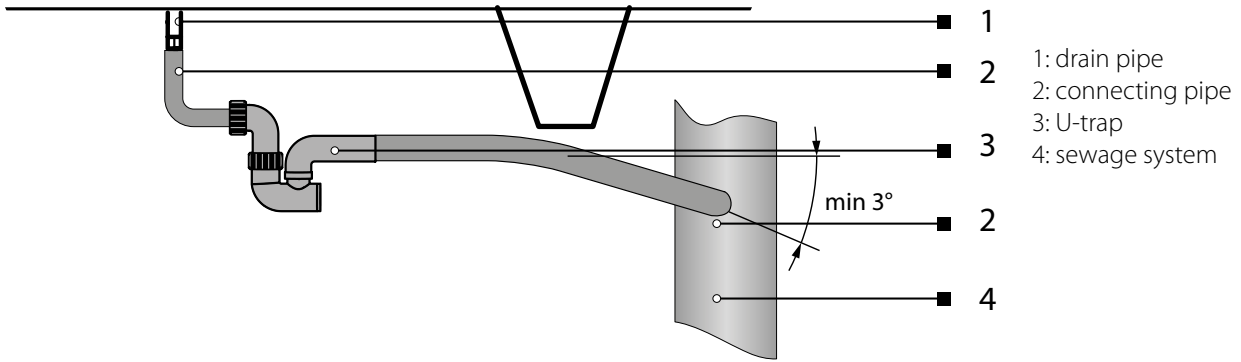

Prior to starting operation make sure that water has unobstructed flow in the sewage system. Fill the U-trap with water before operation.

Connection of the water heater (only for the models with water heater)

While connecting the water heater keep the straight air duct section length not less than 15 3/4" from the unit. Otherwise the maintenance panel cannot be opened!

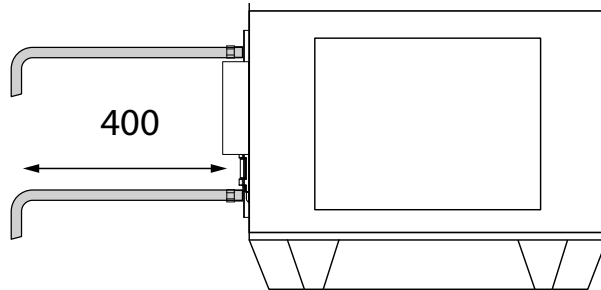

CONNECTION TO POWER MAINS

THE UNIT CONNECTION TO THE POWER SUPPLY MUST BE PERFORMED BY DULY QUALIFIED PERSONNEL MADE FAMILIAR WITH THE PRESENT OPERATION MANUAL.

THE UNIT IS INTENDED FOR CONNECTION TO AC MAINS SUPPLYING THE VOLTAGE COMPLIANT WITH THE TECHNICAL SPECIFICATION CHART. CHECK THE ENTIRE POWER CORD LENGTH FOR CHOKING. DO NOT SWITCH ON THE UNIT IF THE CABLE IS DAMAGED.

DISCONNECT THE UNIT FROM POWER SUPPLY PRIOR TO ANY OPERATIONS.

THE RATED ELECTRICAL PARAMETERS OF THE UNIT ARE STATED ON THE RATING PLATE.



ANY TAMPERING WITH THE INTERNAL CONNECTIONS IS PROHIBITED AND WILL VOID THE WARRANTY.

- The unit must be connected to power mains using durable, insulated and heat-resistant conductors (cables and wires). The actual wire cross section selection must be based on the maximum load current, maximum conductor temperature depending in the wire type, insulation, length and installation method.
- The external power input must be equipped with an automatic circuit breaker built into the stationary wiring to open the circuit in the event of overload or short-circuit. The position of the external automatic circuit breaker must ensure free access for quick power-off of the unit. The trip current of the automatic circuit breaker must exceed the maximum current consumption of the unit (refer to the "Technical data" section). The recommended trip current of the circuit breaker is the next current in the standard trip current row following the maximum current of the connected unit. The automatic circuit breaker is not included in the delivery set and can be ordered separately.

To connect the power cable, perform the following steps:

1. Open the service doors

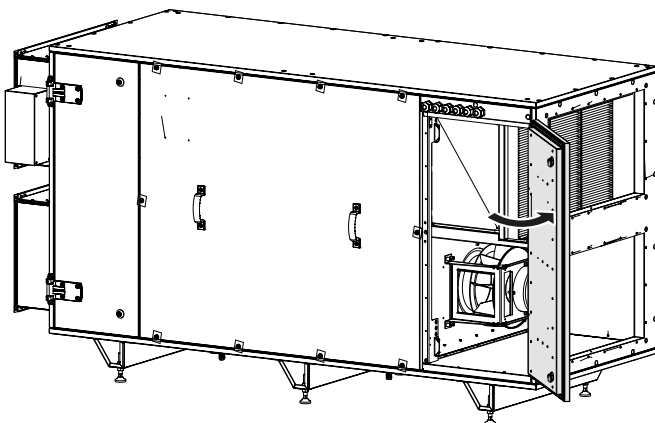

2. Remove the service panel

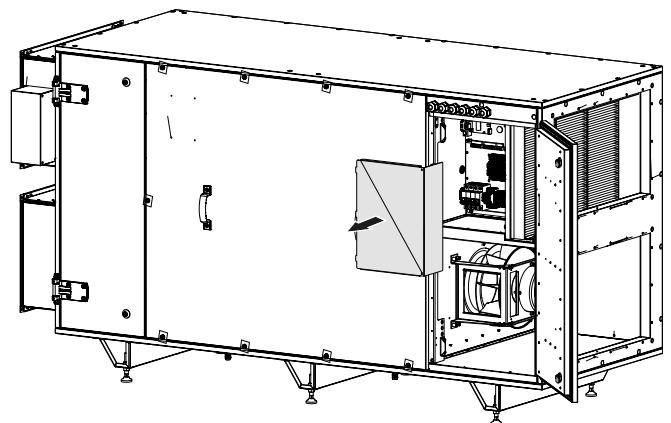

3. Lead the power cable through the cable gland. Fix the power cable with clamps (not included in delivery and ordered separately) and connect it to the terminal block in accordance with the wiring diagram.

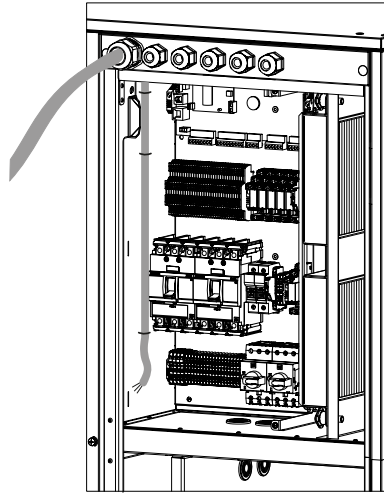

Reassemble the unit in the reverse order

TECHNICAL MAINTENANCE



WARNING – TO REDUCE THE RISK OF FIRE, ELECTRIC SHOCK, OR INJURY TO PERSONS, OBSERVE THE FOLLOWING:

BEFORE REMOVING THE FILTERS, SWITCH OFF THE EXTERNAL AUTOMATIC CIRCUIT BREAKER AND LOCK THE SERVICE DISCONNECTING MEANS, THEN OPEN THE HINGED SERVICE PANEL AND REMOVE THE FILTERS CAREFULLY.

IT IS POSSIBLE TO CLEAN FILTERS WITH A VACUUM CLEANER OR RINSE THEM WITH WATER AND DRY. MAKE SURE FILTERS ARE COMPLETELY DRY BEFORE THEY HAVE BEEN INSTALLED BACK INTO THE UNIT.

OPEN THE UNIT FOR INSPECTION AND SERVICE NOT LESS THAN 2 MINUTES AFTER COMPLETE DE-ENERGIZING OF THE UNIT.

THE FANS ROTATION MAY BE STILL PRESENT.

IN CASE OF ANY ABNORMAL NOISE, SMELL AND COMPONENT DEFORMATION IMMEDIATELY CUT OFF POWER SUPPLY TO THE UNIT AND CONTACT

A SERVICE PROVIDER OR THE UNIT SELLER.

The unit operation requires regular inspection, dry cleaning of inner components, check-up and replacement of air filters in case of filter contamination.

3-6 months after commissioning of the unit it must be inspected by a service expert for planned preventive maintenance of the unit.

Next maintenance operations must be conducted at least every 6-12 months. Maintenance periodicity is determined by a service expert depending on operation conditions of the unit.

Dust deposits on the inner parts of the unit, especially in the electric heater, may lead to unpleasant odours. It is not a malfunction.

Clean the unit to troubleshoot unpleasant odours.

Air damper and air shutter

Check the air dampers periodically.

The shutters and gears may accumulate dust, grease and other contaminants preventing proper operation of the dampers.

If present, remove contamination with compressed air jet.

If such actions fail, subject the damper to a high-pressure wash with a water solution of a detergent non-corrosive to the aluminium surfaces.

Open the service doors to access the filters.

AV07

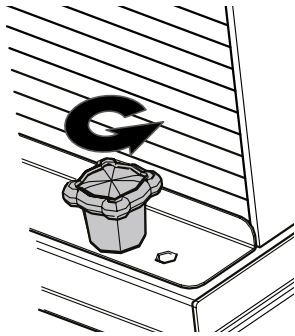

Remove the two butterfly bolts that fix the retaining clamp.

AV02/AV03

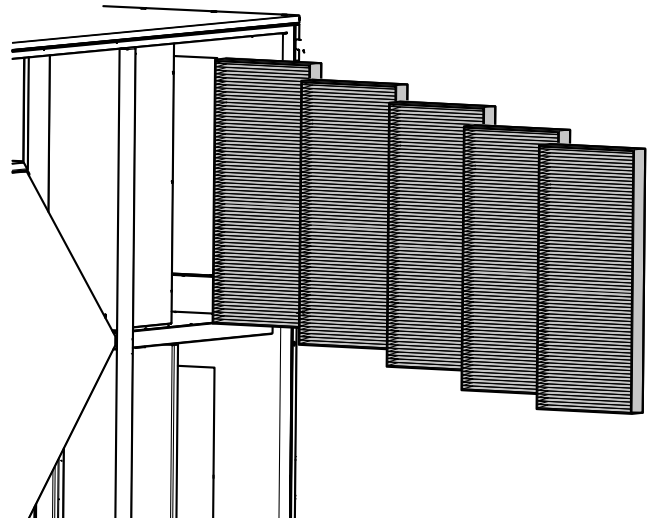
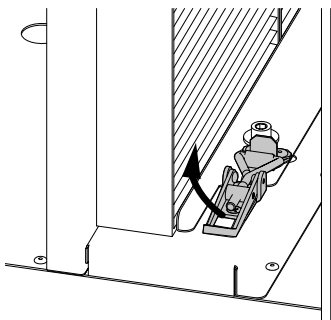

Remove the filter elements.

Open the two latches securing the pressure plate.

To access the heat exchanger remove the service panel.
Loosen the screws (1) on the retaining clamps (2) using a hexagon wrench.

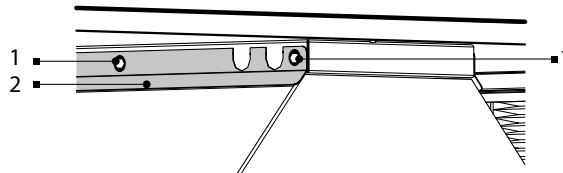

Pull the heat exchanger out.

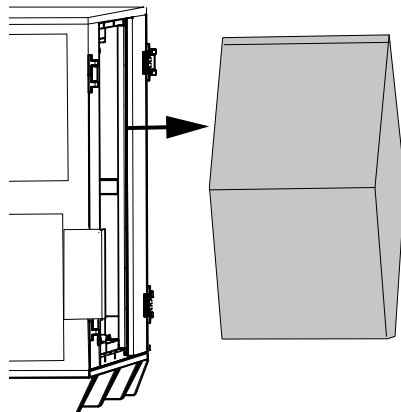

Ventilation equipment maintenance regulation

	Component name	once a week	once per month	every 6 months	once a year
1.	Supply filter*:				
	Inspection of the condition	-	+	-	-
	Dust removal, compressed air jet	-	(!)	+	-
	Replacement	-	-	-	+
2.	Extract filter*:				
	Inspection of the condition	-	+	-	-
	Dust removal, compressed air jet	-	(!)	+	-
	Replacement	-	-	-	+
3.	Control switchboard:				
	Check-up of communication lines and power cables for integrity	-	+	-	-
	Check-up of terminal connections	-	+	-	-
	Check-up of launch protection equipment	-	+	-	-
	Checking controller operation, analysis of error log	+	-	-	-
	Temperature sensor reading analysis	+	-	-	-
	Verification of set parameters of the frequency converter	-	-	-	+
	Verification of the temperature sensor readings	+	-	-	-
	Operation checking of the frequency converter of the rotor drive	-	-	-	+
Operation checking of protective circuit	-	+	-	-	
4.	Water heater:				
	Visual inspection	-	-	+	-
	Cleaning and washing	-	-	-	+
	Operation check-up of the 3-way heat medium control valve (if the system is filled with heat medium) and the circulation pump	-	-	+	-
5.	Electric heater:				
	Visual inspection	-	+	-	-
	Cleaning	-	-	+	-
	Check-up of the electric heating elements	-	-	+	-
6.	Water cooler:				
	Visual inspection	-	+	-	-
	Cleaning (together with the droplet separator)	-	-	-	+
7.	DX cooler:				
	Visual inspection	-	+	-	-
	Cleaning (together with the droplet separator)	-	-	-	+
8.	Cross-flow heat exchanger:				
	Visual inspection	-	+	-	-
	Check-up of the drain pan	-	+	-	-
	Check-up of the drain system and U-trap	-	+	-	-
	Check-up of the bypass damper and damper actuator	-	+	-	-
	Heat exchanger cleaning	-	-	-	+
9.	Rotary heat exchanger:				
	Check-up of the rotor smooth rotation	-	+	-	-
	Check-up of the belt condition and tightening	-	+	-	-
10	Exhaust/Supply air shutters:				
	Check-up of the shutters smooth operation	-	-	+	-
	Checking of the electric actuator and electric connections	-	-	+	-
	Damper cleaning	-	-	+	-

Ventilation equipment maintenance regulation

	Component name	once a week	once per month	every 6 months	once a year
11.	Back airflow damper with shutters				
	Checking air shutters for smooth operation	-	-	+	-
	Checking of the electric actuator and electric connections	-	-	+	-
	Damper cleaning	-	-	+	-
12.	Supply and extract fans:				
	Visual inspection and check-up of the electric motors and impellers	-	+	-	-
	Check-up of the motor fixation and vibration dampers on the mounting frame in the fan section	-	+	-	-
	Check-up of the terminal connections in the motor terminal box	-	-	+	-
	Test run of the motor with and without load	-	-	+	-
	Checking of the impeller fixation to the motor shaft	-	+	-	-
	Checking of the indirect motor heating temperature under the rated operation conditions	-	-	+	-
	Current checking and measuring for each phase	-	-	-	+
	Verification of the frequency converter parameters	-	-	-	+
Cleaning of the impeller and motor from dust	-	-	+	+	

((!)) — more intensive contamination requires more frequent applications.

*— filter cleaning and replacement frequency may vary depending on the region and air pollution degree.

CONTROL MEASUREMENTS OF OPERATING PARAMETERS

The technical maintenance of the unit includes routine measurements of the following parameters:

Correct temperature and humidity of the processed air both upstream and downstream of the air handling unit.

The operating parameters of the components in the connected heating and cooling equipment.

Proper operation of the electrical equipment (power consumption measurements).

Proper operation of the fan groups specific to maintaining the air flow and unit operation parameters.

All the work specific to the routine control measurements and technical maintenance operations must be confirmed with the appropriate documents.

ALARMS			
	Alarm	Alarm source	Possible troubles
1.	Fire signalling	External signal from the fire alarm system. The inputs of the external terminals are closed and the alarm signal is generated.	Check the inlet circuits.
2.	Supply fan	Operation signal from the supply fan frequency converter.	Check the frequency converter settings. Check the parameters of the controller inputs. These parameters must be consistent with the frequency converter parameters.
		Fan pressostat.	Check the fan operation. Check the pressostat operation. Check the thermostat capillary tube mounting.
3.	Extract fan	Operating signal of the extract fan frequency converter.	Check the frequency converter settings. Check the parameters of the controller inputs. These parameters must be consistent with the frequency converter parameters.
4.	Temperature sensor	Malfunction of any temperature sensor	Check the current temperature readings in the controller menu, see "Current status". If the controller reads the temperature -40 °C (-40 °F), it indicates a short circuit in the corresponding sensor circuit. If the controller reads the temperature +150 °C (302 °F), it indicates a circuit breakdown.
5.	Heat exchanger freezing	This alarm is generated if the temperature falls down below the set point within a set time period.	Check the parameters of the control low for the heat exchanger.
			Check the actuating device for operability.
			Check the exhaust air temperature for operability.
6.	Rotary heat exchanger	Operation signal from the rotary heat exchanger frequency converter.	Check the frequency converter settings. Check the parameters of the controller inputs. These parameters must be consistent with the frequency converter parameters.
7.	Heater freezing	Tripping of the freeze protection thermostat of the heater. The freeze protection function is activated also in the summer mode.	Set the thermostat tripping temperature from 8 to 10 °C (47 °F ... 50 °F). Check the thermostat control circuit. Check the settings of the operating contact for compliance.
8.	Low water temperature	Low heat medium temperature at the end of the heating cycle.	Check the heat medium. Check the pump. Check operation of the actuating device. Check heat medium flow.
9.	Low return heat medium temperature	Low heat medium temperature during operation.	Check the heat medium temperature. Check operation of the circulation pump. Check operation of the actuating device. Check heat medium flow and make sure the hydraulic system is not clogged.
10.	Circulation pump	No pump operation control.	Check the pump operability. Check operability of the control unit (pressostat, flow rate sensor, etc.). If a control unit is not available, jump the respective inputs.
11.	Supply filter	Supply filter clogging.	Check for clogging. Check the clogging control device (pressostat).
12.	Extract filter	Extract filter clogging.	Check for clogging. Check the clogging control device (pressostat).
13.	Heater overheating	Tripping of the overheating thermostat.	Check the supply air damper for opening, check the supply filter for clogging, check operability of the actuating device (relay).
14.	Low supply air temperature	Low supply air temperature within 10 minutes (scheduled) is interpreted as underheating.	Check the heating element and control circuit condition. Make sure that the environmental conditions of the installation place match the stated conditions.

TROUBLESHOOTING

	Problem	Possible source.	Troubleshooting method
1.	Filter alarm (clogging).	Filter clogging.	Clean the filter using a vacuum cleaner against air flow direction or install a new filter. (!) Do not wash the filter with water or detergents!
		Malfunction of the pressostat or breakdown of the commutation circuit (NC - normally closed contact).	Check the status of the pressostat or check its circuit (NC - normally closed contact).
2.	Low air flow.	Filter clogging, heater or heat exchanger contamination.	Clean the fan, the heater and the heat exchanger.
		Fan malfunction.	Check power supply to the fan. Check the control system for errors.
		One or two air dampers are closed.	Check the air damper for smooth opening. Check connection to power supply and available control signal on the damper actuator.
		Wrong rotation direction of the fan.	Check the three-phase motor for correct phase sequence. Check the capacitor capacity and its status for the single-phase motor. (!) The rotation direction is shown on the impeller of the ventilation unit.
3.	Water dripping in the unit.	Drain line clogging.	Clean the pipes.
		No U-trap.	Install the U-trap.
		Wrong unit-drain line mounting angle.	Check the installation angle of the air handling unit/drain line for consistence with the data stated in the technical documentation. Correct it if required.
4.	No heating (applicable for the air handling units with an integrated heater)	No power supply to the electric heating elements.	Check power supply to the heater section. Check resistance of each heating element and check them for integrity. In case of any breach on the circuit of the heating element replace it.
		Tripping of the thermal switch TK 90 °C (194 °F).	Press the button ""Reset"" on the thermal switch TK90 for manual reset. (!) Troubleshoot the tripping source for TK90.
		No contact on the electric heating elements.	Press the connection lugs of the heating elements.
		Breaking of the electric heater element (wire breaking)	Replace the electric heating element.
		Breakdown of the solid-state relay.	Check the condition of the solid-state relay using a volt-ohm meter. Normally the relay does not acts as a conductor and is closed.
5.	Water heater/cooler has insufficient heating or cooling capacity.	No heat medium.	Check availability of the heat medium in the hydraulic system, its temperature and pressure.
		Air locks in the hydraulic system.	Deaerate the system.
		No heat medium circulation.	Check power supply to the circulation pump. Check the pump rotor for rotation.
		Malfunction or closing of the mixing unit.	Check power supply to the mixing unit actuator. Check the connection of the actuator to the actuating device.
		Open bypass damper.	Check the bypass damper actuator for jamming. Make sure it is properly connected to power supply and the bypass damper opening procedure matches the control system command.
6.	Abnormal noise generated by the unit.	Direct connection of the air duct to the casing without anti-vibration connector.	Do not allow the air duct to be connected directly to the unit.
		Run-out of the motor bearing service life.	Check rotation of the rotor with idle running. Noise and skirr may indicate the run-out of the bearing service life.
7.	Malfunction of one or two motors.	No power supply to the electric motors.	Check the voltage.
		Motor winding breakdown or turn-to-turn short circuit of the motor winding.	Check resistance of each motor winding using a volt-ohm meter.
		No control signal for EC motors.	Make sure the signal is available for specified status of the control system parameters. Check the control system for errors.
8.	Generation of condensate in inappropriate places in the unit.	Air motion inside of the unit during standstill caused by air draughts because of open dampers or no dampers.	Check operability of the supply and exhaust air dampers.
		Internal air leakages as a result of severe clogging of one or two filters.	Clean the filter using a vacuum cleaner against air flow direction or install a new filter. (!) Do not wash the filter with water or detergents!
		Inappropriate use of the air handling unit.	Check the transported air parameters (humidity + temperature) and the environmental parameters.

STORAGE AND TRANSPORTATION REGULATIONS

- Store the unit in the manufacturer's original packaging box in a dry closed ventilated premise with temperature range +41...104 °F at RH not exceeding 70%.
- Storage environment must not contain aggressive vapours and chemical mixtures provoking corrosion, insulation, and sealing deformation.
- Use suitable hoist machinery for handling and storage operations to prevent possible damage to the unit.
- Follow the handling requirements applicable for the particular type of cargo.
- The unit can be carried in the original packaging by any mode of transport provided proper protection against precipitation and mechanical damage. The unit can be transported only in the working position.
- Avoid sharp blows, scratches, or rough handling during loading and unloading.
- Prior to the initial power-up after transportation at sub-zero temperatures, allow the unit to warm up at operation temperatures for at least 3-4 hours.

MANUFACTURER'S WARRANTY

Production meets standard operating requirements in the USA and Canada.

Vents US warrants to the original purchaser of the unit that it will be free from defects in materials or workmanship for a period of 24 months from the date of original purchase. The Vents US warrants to the original purchaser of the unit that the integrated control unit will be free from defects in materials and workmanship for a period of 24 months from the date of original purchase.

THERE ARE NO OTHER WARRANTIES, EXPRESS OR IMPLIED, INCLUDING, BUT NOT LIMITED TO, IMPLIED WARRANTIES OF MERCHANTABILITY OR FITNESS FOR A PARTICULAR PURPOSE.

During the stated warranty period, Vents US will, at its option, repair or replace, without charge, any product or part which is found to be defective under normal use and service. This warranty does not cover (a) normal maintenance and normal service or (b) any products or parts which have been subject to misuse, negligence, accident, improper maintenance or repair (other than by Vents US), faulty installation or installation contrary to recommended installation instructions. Labor to remove and replace products is not covered. The duration of any implied warranty is limited to the time period specified for the express warranty. Some states do not allow limitations on how long an implied warranty lasts, so the above limitation may not apply to you.

VENTS US OBLIGATION TO REPAIR OR REPLACE, AT VENTS US OPTION, SHALL BE THE PURCHASER'S SOLE AND EXCLUSIVE REMEDY UNDER THIS WARRANTY. VENTS US SHALL NOT BE LIABLE FOR INCIDENTAL, CONSEQUENTIAL OR SPECIAL DAMAGES ARISING OUT OF OR IN CONNECTION WITH PRODUCT USE OR PERFORMANCE.

Some states do not allow the exclusion or limitations of incidental or consequential damages, so the above limitation or exclusion may not apply to you. This warranty gives you specific legal rights, and you may also have other rights which vary from state to state. This warranty supersedes all prior warranties. If proof of sales date is absent, warranty period is calculated from the production date. The unit can be exchanged at the following address:

Vents-US
 400 Murray Road, Cincinnati, OH 45217, USA
 Tel: 1-888-640-0925, 513-583-5786, Fax: 513-268-4597
 E-mail: support@ventsus.com
 www.vents-us.com

Please follow guidelines in this manual for product problem-free operation.



FOLLOWING THE REGULATIONS STIPULATED HEREIN WILL ENSURE A LONG AND TROUBLE-FREE OPERATION OF THE UNIT



USER'S WARRANTY CLAIMS SHALL BE SUBJECT TO REVIEW ONLY UPON PRESENTATION OF THE UNIT, THE PAYMENT DOCUMENT AND THE USER'S MANUAL WITH THE PURCHASE DATE STAMP

CERTIFICATE OF ACCEPTANCE

Unit Type	Air handling unit
Model	
Serial Number	
Manufacture Date	
Quality Inspector's Stamp	

SELLER INFORMATION

Seller	
Address	
Phone Number	
E-mail	
Purchase Date	
This is to certify acceptance of the complete unit delivery with the user's manual. The warranty terms are acknowledged and accepted.	
Customer's Signature	

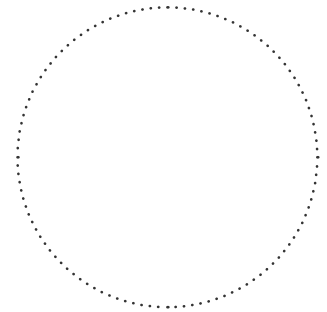

Seller's Stamp

INSTALLATION CERTIFICATE

The _____ unit is installed pursuant to the requirements stated in the present user's manual.	
Company name	
Address	
Phone Number	
Installation Technician's Full Name	
Installation Date:	Signature:
The unit has been installed in accordance with the provisions of all the applicable local and national construction, electrical and technical codes and standards. The unit operates normally as intended by the manufacturer.	
Signature:	

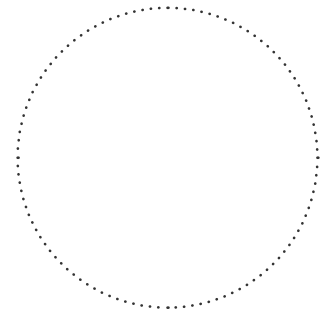

Installation Stamp

WARRANTY CARD

Unit Type	Air handling unit
Model	
Serial Number	
Manufacture Date	
Purchase Date	
Warranty Period	
Seller	

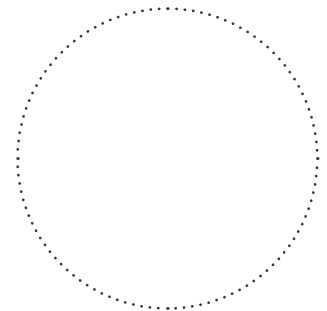

Seller's Stamp

