

LD SERIES

Axial extract fans



DESCRIPTION

Axial extract LD fans are the perfect ventilation solution for modern kitchens, and bathrooms.

The flat, square shaped front cover matches even the most sophisticated interior.

Perfect for contemporary and modern design applications. The fans can be mounted on a wall or ceiling, and are compatible with 4", 5", and 6" ducts. No additional mounting box or special tools needed; easy installation with the help of screws and hose clamp.

The fans can be connected to the supply through a switch, cord or dimmer. Caution: The fans must not be used in bath or shower enclosures.

APPLICATIONS

- Bathroom exhaust
- Kitchen ventilation
- Living area

BENEFITS

- Sizes available from 4", 5", 6"
- Quiet and powerful
- Vibration free operation
- Easy installation
- Corrosion resistant
- UV resistant, UL94 certified plastic
- ETL listed



DIMENSIONS

Model	Measurements [in.]				
	B	H	L	ØD	L1
100 LD	5 15/16"	4 3/4"	4 15/16"	3 15/16"	1 3/16"
125 LD	6 15/16"	5 1/2"	5 5/16"	4 15/16"	1 5/16"
150 LD	8 1/16"	6 1/2"	6 1/16"	5 15/16"	1 3/8"

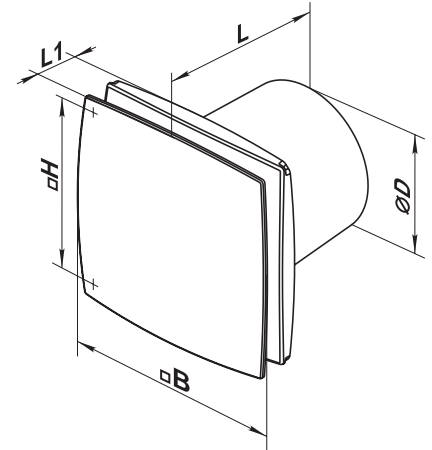
PERFORMANCE

AMCA International Licensed Products

Model	RPM*	Sones	Duct Dia	Watts*	Amps*	CFM vs. Static Pressure (Ps) in WG		Max Ps	Volts
						0"	0.03"		
125 LD	2400	2.16	5"	15.5	0.19	79	63	0.16	120 / 60 Hz
150 LD	2337	3.0	6"	32.9	0.39	109	92		120 / 60 Hz

AMCA International Non-Licensed Products

Model	RPM*	Sones	Duct Dia	Watts*	Amps*	CFM vs. Static Pressure (Ps) in WG		Max Ps	Volts
						0"	0.03"		
100 LD	2975	1.37	4"	13.9	0.18	44	42	0.15	120 / 60 Hz

SPECIFICATION

- Voltage: 120 V, 60 Hz
- Motor: AC motor
- Duct compatibility: Ø 4", 5", 6"
- Airflow capacity: up to 109 CFM
- Sones: 1.37 - 3.0
- Power consumption: 13.9 - 32.9 W
- Suitable for working airstreams up to 113 °F
- IPX4 protection
- Thermal overload protection
- Mounting bracket and power cord included