

## HEAT RECOVERY VENTILATION UNIT RV

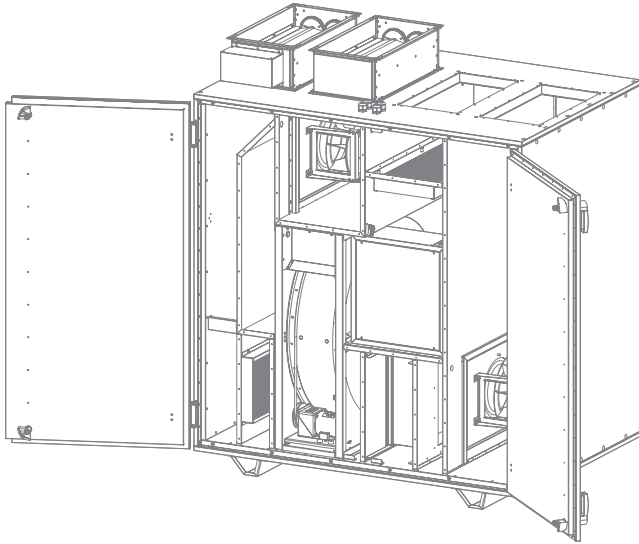

The brand new premium line of commercial heat recovery air handling units for floor mounting with high-efficient heat exchanger. Available in 7 standard sizes based on the air flow capacity of 470, 705, 880, 1400, 2000, 3000, 3500 CFM. Optionally accomplished with electric heater or water heater and ready for operation with all necessary control elements.

### Main features:

- High-efficient EC fans, backward-curved, external rotor. Low power consumption at any speed, low noise level and stable operation in any climate conditions.
- Integrated plug-and-play controls on the basis of the Carel controller. Easy connecting via web-interface using the Ethernet-Modbus and BACnet.
- Insulated double-skin frameless casing.
- High-efficient aluminum rotary heat exchanger.
- The casing panels are made of steel with zinc-aluminium coating and internally lined with 1<sup>9/16</sup>" heat- and sound-insulating mineral wool layer. The units have C4 corrosion resistance class in compliance with ISO 12944. Each model is available in left- and right-handed modifications. The units have service access on both sides and on the bottom.
- Washable MERV13, MERV8 (optional) panel filters in exhaust and supply air streams.
- Integrated control panels:
  - A30 th-Tune: standard control panel with handy interface ensures basic setup of parameters.
  - A32 pGDe: control panel with expanded functionality ensures complete setup of parameters.
- Integrated automatic external dampers with Belimo actuators.
- ECO-Design'18 compliant.

### Technical parameters

Model	RV 800	RV 1200	RV 1500	RV 2500	RV 3500	RV 5000	RV 6000	
Nominal air flow [CFM]	470	705	883	1471	2060	2943	3531	
EC fans	phase/voltage [50–60 Hz/VAC]		1~200/240			3~380/480		
	power/current [kW/A]		2x0.28/2.5	2x0.61/5.3	2x0.61/5.3	2x0.835/7.6	2x1.23/3.95	2x1.41/3.95
	fan speed [min <sup>-1</sup> ]		2800	3000	3000	3000	2400	1700
	perm. amb. temp. [°F]		-31...+122					
	motor protection		IP54					
	insulation class		F					
Filter class exhaust/supply standard (optional)		MERV13 (MERV8)/MERV13 (MERV8)						
Weight (net, without packaging) [lb]		595	595	676	676	893	1576	
Lpa (to environment), 3 m [dBA]		35	36	35	39	41	40	

Overall dimensions [in]

Dimensions [in]	RV 800	RV 1200	RV 1500	RV 2500	RV 3500	RV 5000	RV 6000
L	44.88	44.88	55.12	55.12	62.99	75.20	75.20
W	30.91	30.91	37.80	37.80	50.79	54.72	54.72
H	49.21	49.21	55.12	55.12	73.23	82.28	82.28
H1	∅ 9.84	∅ 9.84	9.84	9.84	11.81	19.69	19.69
S1	-	-	19.69	19.69	23.62	39.37	39.37

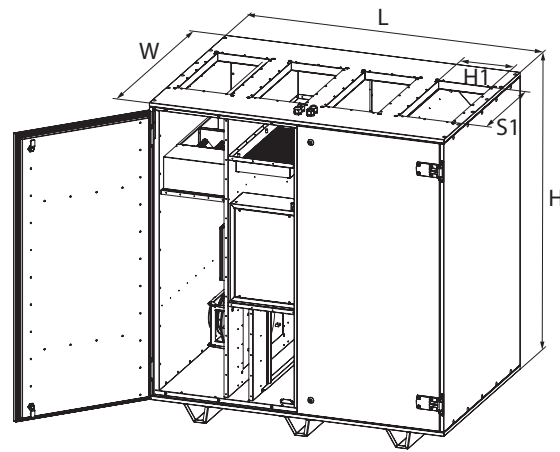

RV 800

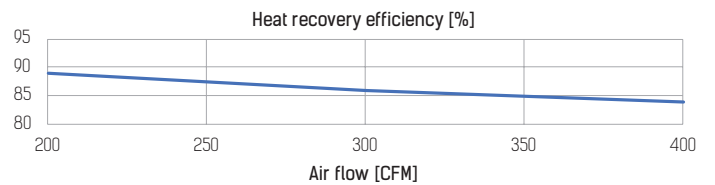
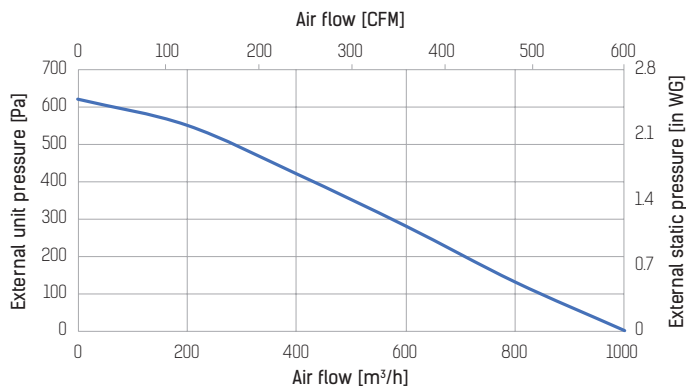

## RV 1200

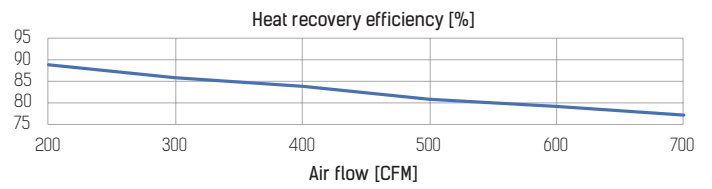
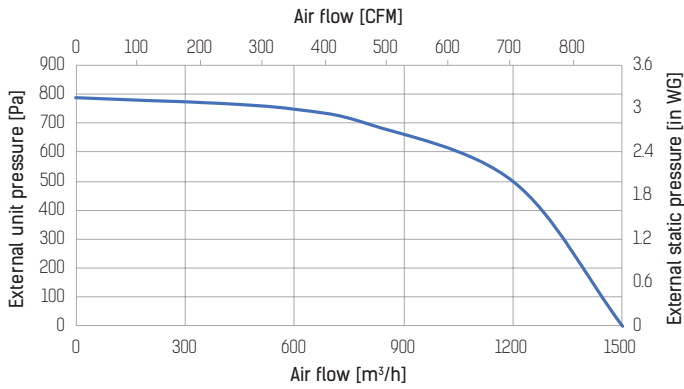

## RV 1500

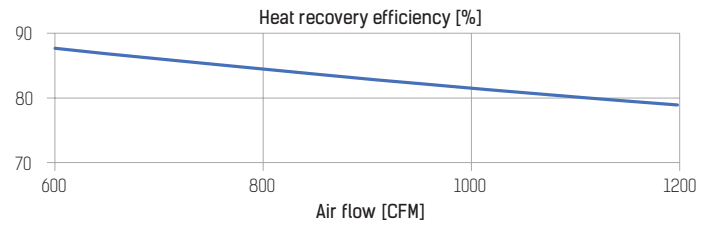
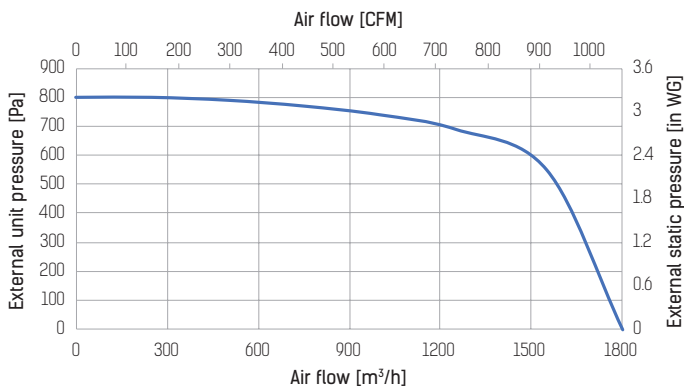

## RV 2500

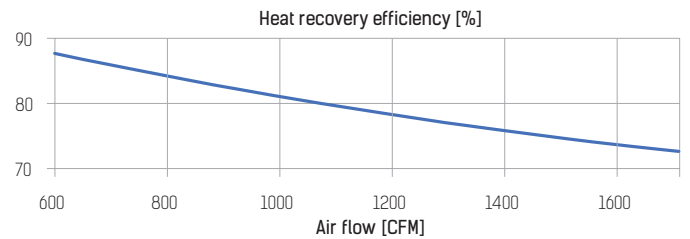
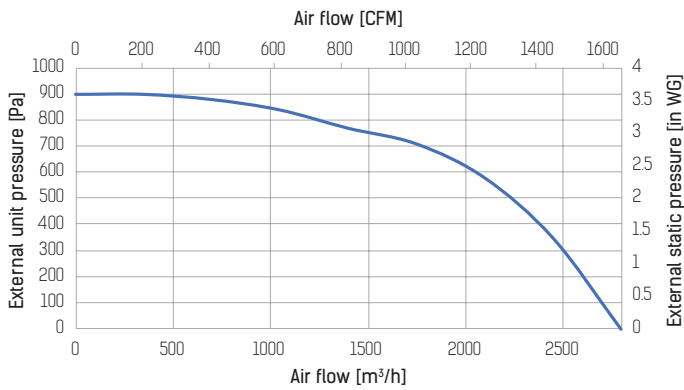

## RV 3500

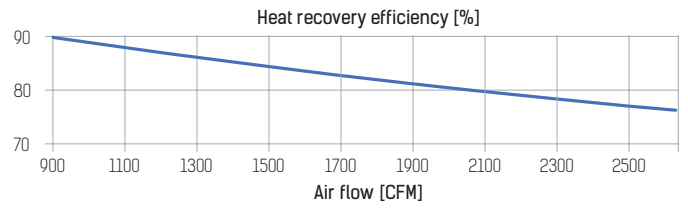
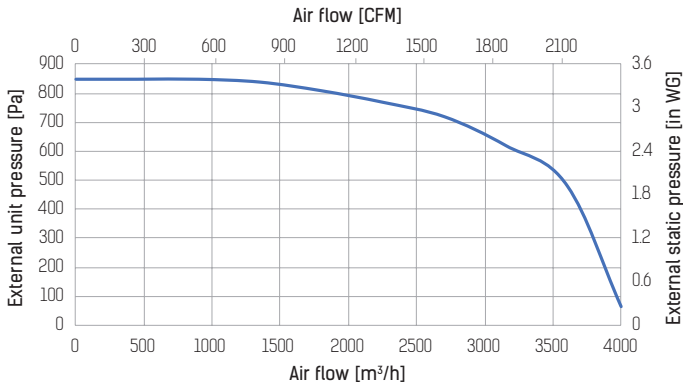

## RV 5000

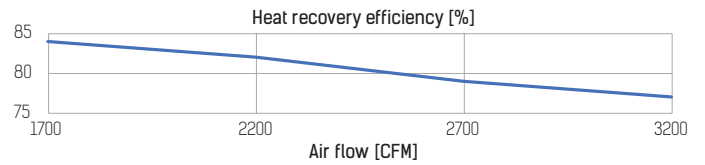
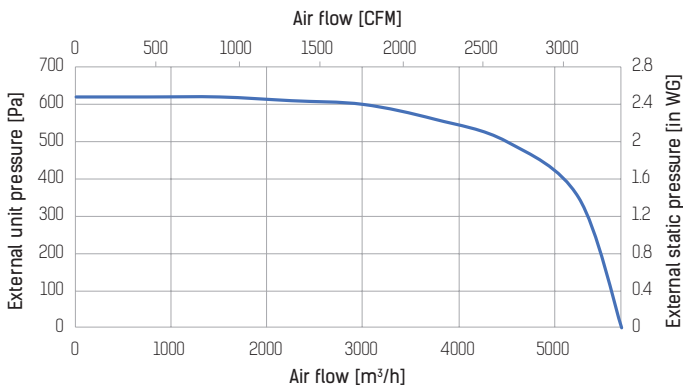

## RV 6000

